

Sealing solutions

SKF Polyseal

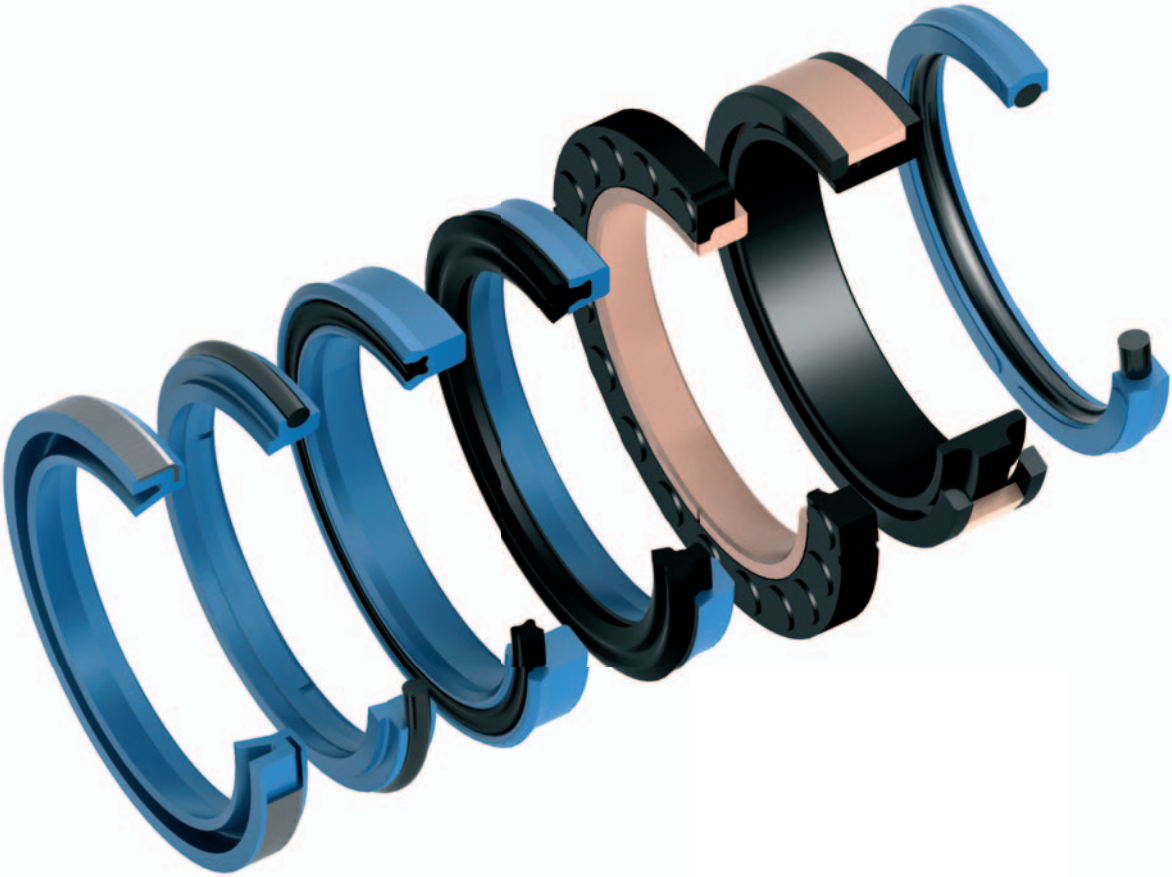



The SKF brand now stands for more than ever before, and means more to you as a valued customer.

While SKF maintains its leadership as the hallmark of quality bearings throughout the world, new dimensions in technical advances, product support and services have evolved SKF into a truly solutions-oriented supplier, creating greater value for customers.

These solutions encompass ways to bring greater productivity to customers, not only with breakthrough application-specific products, but also through leading-edge design simulation tools and consultancy services, plant asset efficiency maintenance programmes, and the industry's most advanced supply management techniques.

The SKF brand still stands for the very best in rolling bearings, but it now stands for much more.

SKF – the knowledge engineering company

Contents

About SKF Polyseal	3	Piston seals	46
Seal selection	4	O-ring energized piston rings	46
Performance and leakage control index . .	5	Product table, metric sizes	47
Material – Thermoset	6	Product table, inch sizes	48
Material – Thermoplastic	8	Square ring energized piston rings	49
Fluid compatibility	10	Product table, metric sizes	50
Spectraseal seal jacket compounds	11	Crown piston seal	52
Surface finish recommendations	12	Product table, metric sizes	53
Storage recommendations	14	Product table, inch sizes	54
Rod seals	16	Locking T seals	56
UBR Polyurethane U Cups and rod seals . .	16	Product table, metric/inch sizes . . .	58
Product tables, metric sizes	18	Polyurethane piston seals	61
Product tables, inch sizes	20	Product table, metric sizes	62
Buffer seals	27	Grooved piston rings	66
Product tables, metric sizes	28	Product table, metric sizes	68
Product tables, inch sizes	30	Product table, inch sizes	69
Spectraseals	32	Capped T piston seal	70
Product table, Rod style gland	36	Product table, metric sizes	73
Product table, Piston style gland	37	Guide rings	74
Rod wipers	38	Close tolerance guide rings	74
Press-fit wipers	38	Installation guide	76
Product table, metric sizes	39	SKF – the knowledge engineering company	80
Product table, inch sizes	40		
Snap-in wipers	41		
Product table, metric sizes	42		
Product table, inch sizes	43		

About SKF Polyseal

SKF Polyseal is a leading manufacturer and supplier of hydraulic seals, excluders, engineered plastics and precision machined guide rings used in the fluid power and fluid processing industry. Our factory, located in Salt Lake City, Utah, USA, is a fully integrated manufacturing facility that combines advanced technology and quality assurance capabilities into over 30 000 m² (322 000 ft²) of floor space.

Established in 1973, SKF Polyseal has been built on a continuous commitment to quality, innovation and customer service by using the latest technology and on-going facility upgrades to meet customer expectations. Dedication to production of the best product for the application has brought SKF Polyseal significant attention and growth with OEMs and end-users of equipment used for; Mining, Construction, Material Handling, Agricultural and a wide-range of other equipment used in the fluid power and fluid processing industry. At SKF Polyseal, "sealing solutions" are provided every day to our customers.

As an ISO 9001:2000 registered company, Quality Assurance in process control is documented and retained for validation requirements. Control of environmental issues are standardized by certification of ISO 14001 and Health & Safety are managed by conformance to OSHAS 18001 requirements.

The primary manufacturing techniques used by SKF Polyseal include:

- Injection molding of thermoplastic materials such as; Urethane, Hytrel*, Acetal, Polyester and various grades of Nylons
- Compression molded thermoset elastomers such as; NBR, FKM, XNBR, HNBR and Genuine Viton*
- Machined engineered plastics such as; Unfilled PTFE, many grades of Filled PTFE, PEEK, PPS, Nylon and UHMWPE
- Precision machined guide rings in reinforced rigid plastics
- Net-molded rigid plastic commercial products for special applications

By utilizing multiple manufacturing processes, SKF Polyseal has the ability to offer an extended range of products to meet the wide-range of applications in the fluid power and fluid processing industries. From design, in-house development of molds, tooling and compounding of materials, SKF Polyseal offers the right product for specific applications and for demanding service requirements.

Engineering Support

At SKF Polyseal, our primary focus is dedication to serving customers' needs. Our Product Engineering group works with strategic channel partners (including a vast global network of independent distributors that specialize in fluid sealing products), fluid power component manufacturers and major OEM accounts to develop the right "Sealing Solution" for difficult and constantly evolving fluid sealing applications.

Expert Technical Support provided by our engineering team includes:

- Assistance with the selection, design and use of fluid sealing products for custom applications
- Assistance with failure analysis and system operation
- Product testing to meet customer criteria and performance standards
- Technical training at both Basic and Advanced levels to meet your specific needs

Production

As part of the SKF brand, SKF Polyseal has access to technological resources that only a world-class company can develop. Use of advanced manufacturing techniques and quality programs ensure all finished products adhere to the highest standards in the industry. Through implementation of Six Sigma and development of proprietary processes, SKF Polyseal products are shipped to market with the highest measure of repeatability and consistency. With thermoplastic injection molding capabilities from 2 to 1 150 mm, rubber compression molding capabilities up to 600 mm, machined engineered plastics capabilities up to 1 500 mm and rigid plastics capabilities up to 450 mm, SKF Polyseal offers the widest range of products and material combinations to end-users in the fluid power and fluid processing market.

* Hytrel™, Viton™ and Genuine Viton™ are registered trademarks of DuPont.

Seal selection

There are many types of rod and piston seals available. Many seal types are available in several materials. The products recommended in this manual are the most frequently chosen products. SKF Polyseal engineering personnel can help with choices among a broad range of products including the rod and piston seals described in this manual. Here you will find general guidelines that will assist in the product selection process. For more detailed assistance, please contact an SKF Polyseal engineer.

There are nine basic application considerations that may affect your product selection. These nine considerations generally are considered in the following order:

1 Fluid media

This will determine the types of seal material and seal type that may be suitable for the application. Care should be taken to consider seal types that are available in suitable materials. For use in specific fluids, consult with SKF Polyseal engineering.

2 Service temperature

The minimum and maximum service temperature of the seal and fluids will further determine which materials and seal types are suitable. For general guidelines, refer to the application profiles.

3 Pressure and clearance gaps

The maximum pressure and application clearance gap will determine the risk of seal extrusion failure in the application. Maximum pressure and clearance gap recommendations are available for each seal type for a variety of temperatures. Basic fluid pressure capabilities may be determined from the application profiles.

4 Leakage and drift expectation

Rod seal film control and piston seal drift leakage varies between seal types. Where leakage control is critical, a seal type should be selected that has a high leakage control index. See the performance and leakage control index or contact SKF Polyseal engineering for assistance.

5 Ancillary performance criteria

Friction: Does the application require a seal with a precise level of friction?

Stability: At high linear velocities, seal stability may be an issue. Stability varies between seals.

Contamination: Many seal types are somewhat resistant to fluid contamination and solid particles.

Some seal types are easily damaged in poorly controlled environments.

Care should be taken to select among seal types that are resistant to these issues if they are present in the application.

6 Retrofit and gland size

Many seal types are available to fit the same gland size. Seal gland size varies among seal types also. Care should be taken to select a seal type that will fit the required existing gland or fit in the space available for a new gland specification.

7 Assembly

Some seal types are easily installed without special tools. Other seal types may be more difficult to install. Seals with split anti-extrusion rings may be particularly difficult to install past threads, ports and retaining ring groove. Consult with SKF Polyseal engineering for specific seal installation inquiries.

Performance and leakage control index

Lip squeeze

Lip seals

Low friction
Low wear
Increased leakage

Squeeze seals

Higher friction
Higher wear
Reduced leakage

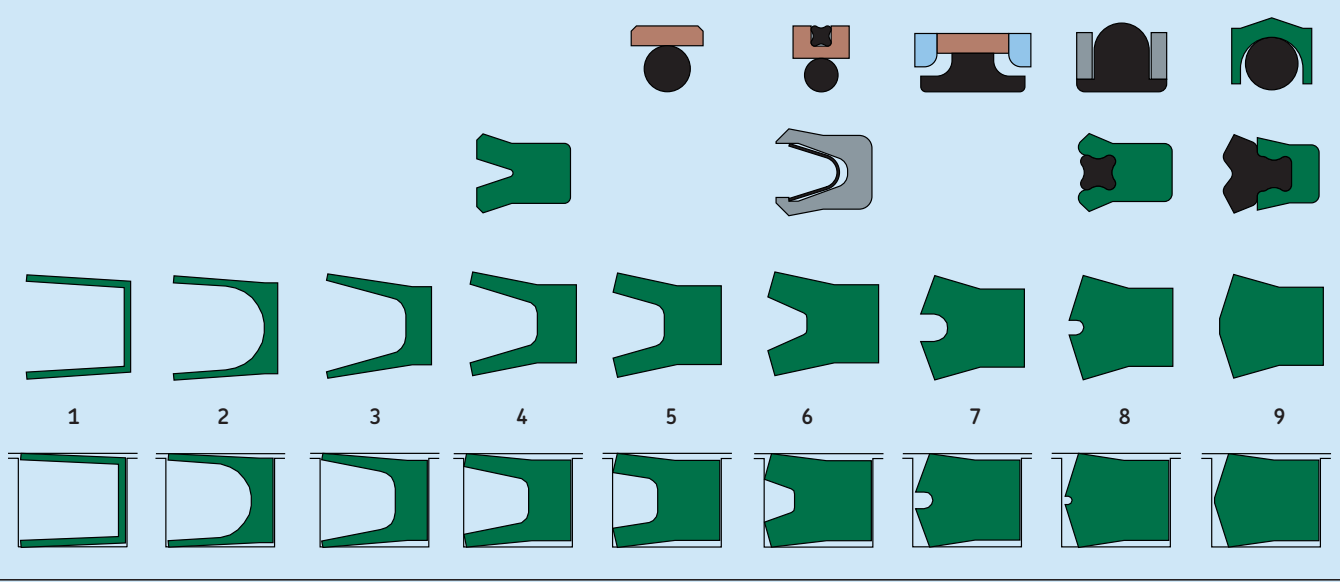

Lip configuration

	Seal sample	Lip shape	Lip installed	Contact stress pattern	Leakage control	Hydroplaining resistance	Contaminated environments
1					High	High	Poor
2					High	High	Good
3					Medium	Medium	Poor
4					Low	Low	Good
5					Low	Low	Excellent

Material – Thermoset

Thermoset	Temperature	Compound features and recommended service
A-8501 – NBR, 70A Nitrile	-37 to +129 °C (-35 to +265 °F)	Petroleum oils, water glycols, water/oil emulsions and many synthetics. Not recommended for use where exposed to sunlight or ozone.
A-8502 – NBR, 80A Nitrile	-37 to +129 °C (-35 to +265 °F)	Petroleum oils, water glycols, water/oil emulsions and many synthetics. Not recommended for use where exposed to sunlight or ozone.
A-8503 – NBR, 90A Nitrile	-37 to +129 °C (-35 to +265 °F)	Petroleum oils, water glycols, water/oil emulsions and many synthetics. Not recommended for use where exposed to sunlight or ozone.
A-8504 – NBR, 70A Nitrile, low temperature	-54 to +115 °C (-65 to +240 °F)	Petroleum oils, water glycols, water/oil emulsions and many synthetics. Not recommended for use where exposed to sunlight or ozone.
A-8508 – NBR, 80A Nitrile, low friction	-37 to +129 °C (-65 to +240 °F)	Petroleum oils, water glycols, water/oil emulsions and many synthetics. Not recommended for use where exposed to sunlight or ozone.
A-8517 – NBR, 70A Nitrile, low friction	-37 to +129 °C (-65 to +240 °F)	Petroleum oils, water glycols, water/oil emulsions and many synthetics. A-8517 also has a friction reducing agent to lower the coefficient of friction. Not recommended for use where exposed to sunlight or ozone.
C-7001 – XNBR, 70A Carboxylated Nitrile	-18 to +135 °C (0 to +275 °F)	Improved abrasion, fluid and wear resistance. Carboxylated Nitriles have a very good high temperature resistance. Not recommended for use in cold weather.
C-7003 – XNBR, 90A Carboxylated Nitrile	-18 to +135 °C (0 to +275 °F)	Improved abrasion, fluid and wear resistance. Carboxylated Nitriles have a very good high temperature resistance. Not recommended for use in cold weather.
C-7008 – XNBR, 85A Carboxylated Nitrile	-18 to +135 °C (0 to +275 °F)	Improved abrasion, fluid and wear resistance. Carboxylated Nitriles have a very good high temperature resistance. Not recommended for use in cold weather.
C-7018 – HNBR, 75A, oil resistant Hydrogenated Nitrile	-29 to +160 °C (-20 to +320 °F)	Higher strength, abrasion and chemical resistance. Not recommended for use with strong acids or chlorinated hydrocarbons.
C-7019 – HNBR, 90A, oil resistant Hydrogenated Nitrile	-29 to +160 °C (-20 to +320 °F)	Higher strength, abrasion and chemical resistance. Not recommended for use with strong acids or chlorinated hydrocarbons.
C-7021 – HNBR, 75A, fluid power highly saturated Nitrile	-40 to +149 °C (-40 to +300 °F)	Higher strength, abrasion and chemical resistance. Superior in aliphatic hydrocarbons and water or steam up to 149 °C (300 °F). Wide temperature range make it suitable for conditions requiring resistance to fuel, fluids and oxidation. Not recommended for use with strong acids or chlorinated hydrocarbons.

The above temperature ranges is only for general guidance. Customer must decide suitability for their purpose.

Thermoset	Temperature	Compound features and recommended service
C-7022 – HNBR, 80A, fluid power highly saturated Nitrile	-51 to +149 °C (-60 to +300 °F)	Higher strength, abrasion and chemical resistance. Superior in aliphatic hydrocarbons and water or steam up to 149 °C (300 °F). Wide temperature range making it suitable for conditions requiring resistance to fuel, fluids and oxidation. Not recommended for use with strong acids or chlorinated hydrocarbons.
E-8001 – EPR, 70A, Ethylene Propylene	-54 to +149 °C (-65 to +300 °F)	Excellent resistance to phosphate ester based fluids, steam Ketones, alcohol and non-petroleum automotive brake fluid. Not recommended for use with petroleum based fluids.
E-8003 – EPR, 90A, Ethylene Propylene	-54 to +149 °C (-65 to +300 °F)	Excellent resistance to phosphate ester based fluids, steam Ketones, alcohol and non-petroleum automotive brake fluid. Not recommended for use with petroleum based fluids.
V-7501 – FKM, 75A, Fluorocarbon rubber	-29 to +204 °C (-20 to +400 °F)	Commonly used in petroleum fluids and also in mild acids, halogenated hydrocarbons and many phosphate ester fluids. Not recommended for Ketones, Amines or steam.
V-7503 – FKM, 90A, Fluorocarbon rubber	-29 to +204 °C (-20 to +400 °F)	Commonly used in petroleum fluids and also in mild acids, halogenated hydrocarbons and many phosphate ester fluids. Not recommended for Ketones, Amines or steam
V-7512 – FKM, 90A, GF, Fluorocarbon rubber	-29 to +204 °C (-20 to +400 °F)	Commonly used in petroleum fluids and also in mild acids, halogenated hydrocarbons and many phosphate ester fluids. Not recommended for Ketones, Amines or steam
V-7521-FKM, 75A, Fluoroelastomer	-29 to +204 °C (-20 to +400 °F)	Viton is a Dupont-Dow trade mark for their Fluoroelastomer (FKM). Viton is highly resistant to fluids and temperatures. Recommended for use from -29 to +204 °C (-20 to +400 °F), it is commonly used in petroleum fluids and also mild acids, halogenated hydrocarbons any many phosphates ester fluids. It is not recommended for ketones, amines or steam. V-7521 is a 75 shore A Viton FKM commonly used for compression seals such as T-seals and Z-lips.
V-7523-FKM, 90A, Fluoroelastomer	-29 to +204 °C (-20 to +400 °F)	Viton is a Dupont-Dow trade mark for their Fluoroelastomer (FKM). Viton is highly resistant to fluids and temperatures. Recommended for use from -29 to +204 °C (-20 to +400 °F), it is commonly used in petroleum fluids and also mild acids, halogenated hydrocarbons any many phosphates ester fluids. It is not recommended for ketones, amines or steam. V-7523 is a 90 shore A Viton FKM commonly used for compression seals such as standard rod seals, lip seals and wipers.

The above temperature ranges is only for general guidance. Customer must decide suitability for their purpose.

Material - Thermoplastic

Thermoplastic	Temperature	Compound features and recommended service
U-1003, 95A, Lubrithane	-54 to +104 °C (-65 to +220 °F)	Ideal for high pressure rod seals, piston seals and wiper applications in most petroleum based fluids. Not recommended for solvents or acids. Not suitable for water above 66 °C (150 °F).
U-1004, 55D, Lubrithane	-54 to +104 °C (-65 to +220 °F)	Ideal for high pressure rod seals, piston seals and wiper applications in most petroleum based fluids. Not recommended for solvents or acids. Not suitable for water above 66 °C (150 °F). Ok in other environments up to 104 °C (220 °F).
U-1023, 93A, Lubrithane	-54 to +121 °C (-65 to +250 °F)	Ideal for high pressure rod seals, piston seals and wiper applications in most petroleum based fluids. Not recommended for solvents or acids. Not suitable for water above 66 °C (150 °F). Ok in other environments up to 104 °C (220 °F).
U-1027, 93A, high temperature Lubrithane	-54 to +135 °C (-65 to +275 °F)	Ideal for high pressure rod seals, piston seals and wiper applications in most petroleum based fluids. Not recommended for solvents or acids. Not suitable for water above 66 °C (150 °F). Ok in other environments up to 104 °C (220 °F).
U-1029, 94A, Lubrithane	-54 to +121 °C (-65 to +250 °F)	Ideal for high pressure rod seals, piston seals and wiper applications in most petroleum based fluids. Not recommended for solvents or acids. Not suitable for water above 66 °C (150 °F). Ok in other environments up to 104 °C (220 °F).
U-1035, 97A, Lubrithane	-54 to +121 °C (-65 to +250 °F)	Ideal for high pressure rod seals, piston seals and wiper applications in most petroleum based fluids. Not recommended for solvents or acids. Not suitable for water above 66 °C (150 °F). Ok in other environments up to 104 °C (220 °F).
F-1504, Fluorotrel 55D	-54 to +135 °C (-65 to +275 °F)	Suitable for higher temperatures and hostile fluids. Fluorotrel has excellent chemical resistance and may be used in water or phosphate ester fluids (except Skydrol) up to 82 °C (180 °F). Consult SKF Polyseal for specific recommendations (intermittent application temperature range of -54 to +149 °C (-65 to +300 °F).





The above temperature ranges is only for general guidance. Customer must decide suitability for their purpose.

Thermoplastic	Temperature	Compound features and recommended service
F-1507, Fluorotrel 50D	-54 to +135 °C (-65 to +275 °F)	Suitable for higher temperatures and hostile fluids. Fluorotrel has excellent chemical resistance and may be used in water or phosphate ester fluids (except Skydrol) up to 82 °C (180 °F). Consult SKF Polyseal for specific recommendations (intermittent application temperature range of -54 to +149 °C (-65 to +300 °F).
H-3004, Hytrel 55D	-54 to +135 °C (-65 to +275 °F)	Hytrel is a trademark of DuPont-Dow. It is suitable for higher temperatures and hostile fluids and provides excellent chemical resistance and may be used in water or phosphate ester fluids (except Skydrol) up to 82 °C (180 °F). Consult SKF Polyseal for specific recommendations (intermittent application temperature range of -54 to +149 °C (-65 to +300 °F).
H-3005, Hytrel 63D	-54 to +135 °C (-65 to +275 °F)	Hytrel is a trademark of DuPont-Dow. It is suitable for higher temperatures and hostile fluids and provides excellent chemical resistance and may be used in water or phosphate ester fluids (except Skydrol) up to 82 °C (180 °F). Consult SKF Polyseal for specific recommendations. H-3004 has and intermittent application temperature range of -54 to +149 °C (-65 to +300 °F).
P-2506, Nylon	-54 to +121 °C (-65 to +250 °F)	Nylon 6/12 material is ideal for auxiliary backup devices for higher pressure and temperature sealing applications. Not suitable for use in systems where water may be present.
P-2518, Acetal	-40 to +121 °C (-40 to +250 °F)	Acetal material is ideal for auxiliary backup devices for higher pressure and temperature sealing applications (recommended for use in systems where water may be present).
P-2551, Nylon GFR	-240 to +121 °C (-400 to +250 °F)	Excellent bearing material for reciprocating motion where lubrication is present. Not suitable for use in systems where water may be present.
P-2552, Nylon PTFE GFR	-240 to +121 °C (-400 to +250 °F)	Excellent bearing material for reciprocating motion where lubrication is present. Not suitable for use in systems where water may be present.

The above temperature ranges is only for general guidance. Customer must decide suitability for their purpose.

Fluid compatibility

	H ₂ O	H ₂ O based hydraulic fluid	Petroleum oil	Phosphate ester	DOT 3 brake fluid	Bio. hydraulic fluid (vegetable based)	Bio. hydraulic fluid (ester based)	ATF	Diesel fuel
NBR Nitrile	A	A	A	NR	NR	A	A	A	A
LT NBR Nitrile	A	A	A	NR	NR	A	A	A	A
XNBR Nitrile	A	A	A	NR	NR	A	A	A	I
HNBR Nitrile	A	A	A	NR	NR	A	A	A	A
EPR or EPDM	A	I	NR	I	A	NR	NR	NR	NR
FKM	A	A	A	A	NR	A	A	A	B
Lubrithane	B	B	A	NR	NR	B*	B*	A	B
Fluorotrel	B	B	A	I	B	A	A	A	B
Polyamide Nylon	B	B	A	NR	A	A+	A	A	A
PTFE	A	A	A	A	A	A	A	A	A

	(A) Good
	(B) Temperature dependent
	(NR) Not recommended
	(I) Contact SKF Polyseal engineering

* 65C (150F) max if fluid has entrained water.

+ Presence of moisture may cause nylon to swell.

Information is based on specific conditions and limited sample size and is only for general guidance. It does not supersede published data for the product. Customer must decide suitability for their purpose.

Spectraloy compound number	Temperature rating				*Wear resistance	*Chemical resistance	*Mating surface hardness	Compound features and recommended service
	from	to	from	to				
–	°C		°F		–	–	–	–
700	–268	+232	–450	+450	P	E	A	Unfilled PTFE: Used predominately for static or slow speed/intermittent service. Excellent for cryogenic service.
716	–268	+260	–450	+500	F	E	A	15% graphic filled PTFE: Very low coefficient of friction. Used in low-pressure dynamic applications that are friction sensitive.
755	–268	+288	–450	+550	G	G	A	Ekonal filled PTFE: Good wear resistance but is not abrasive against non-hardened surfaces. Should not be used in steam applications.
756	–268	+288	–450	+550	E	G	A	Polyimide filled PTFE: Excellent wear resistance but is not abrasive against non-hardened surfaces. Should not be used in steam applications.
771	–268	+288	–450	+550	E	G	B	Mineral moly filled PTFE: Excellent wear resistance. Typically used for dynamic sealing at higher temperatures and pressures.
721	–268	+288	–450	+550	G	G	B	Mineral filled PTFE: Filler is an FDA approved mineral. Used for sealing food products at temperatures greater than 80 °C (176 °F).
734	–268	+288	–450	+550	G	E	B	10% carbon graphite filled PTFE: General-purpose material. Suitable for dynamic sealing of steam and water.
702	–268	+288	–450	+550	E	E	C	Glass, moly filled PTFE: Excellent wear and creep resistance at elevated temperatures. Good abrasion resistance for sealing non-lubricated service at high temperatures and pressures.
703	–268	+288	–450	+550	E	E	C	PPS, carbon and moly filled PTFE: Excellent wear rate in non-lubricated service at high temperatures and pressures.
782	–268	+288	–450	+550	E	E	C	Carbon fiber filled PTFE: Excellent wear and creep resistance at elevated temperatures. Good abrasion resistance for sealing non-lubricated media at elevated temperatures.
790	–268	+288	–450	+550	E	E	C	Carbon fiber filled modified PTFE: Similar to #782 but modified polymer improves wear and product surface finish. Good abrasion resistance for sealing non-lubricated media at elevated temperatures.
711	–268	+288	–450	+550	E	E	C	25% carbon graphite filled PTFE: Similar to #734 but additional filler improves wear, creep and extrusion resistance especially at elevated temperatures.
741	–268	+288	–450	+550	E	P	B	40% bronze filled PTFE: Suited for high-speed dynamic sealing of lubricating media. Should not be used for chemical service.
776	–268	+82	–450	+180	E	G	A	UHMWPE: FDA and USDA 3A approved. Best material for reciprocating service in water or water-based fluids. Typically used for sealing food products, paints, adhesives and resins. Excellent abrasion resistance.
745	–73	+288	–100	+550	G	G	B	Unfilled PEEK: High strength material predominately used for anti-extrusion devices. Suitable for sealing non-lubricating, viscous fluids from ambient to 288 °C (550 °F).

* Material comparison: E = Excellent G = Good F = Fair P = Poor

Surface finish recommendations

R_a = Arithmetic average roughness

R_a is now the universally official symbol for the parameter that was formerly called AA (Arithmetic Average) in the United States and CLA (Center Line Average) in England.

The “checkmark” symbol used on drawings to specify a surface texture control requirement is an R_a specification.

If you add together the lengths and all the vertical lines from the mean line to the profile, considering all the lengths as positive whether they're above or below the mean line, and then divide the total by the number of vertical lines, you would have a pretty good approximation of R_a .

R_a then is the arithmetic average of the absolute distance of all profile points from the mean line in one cut-off.

R_q = RMS (root mean square)

R_q is similar to R_a . It uses the same infinitely long series of roughness profile heights on one cut-off and it averages all of them – but it does the averaging in a different way.

To find the arithmetic average (R_a) of six numbers: 3, 2, 1, 4, 7 and 2, add them all together and divide by 6.

Arithmetic average

$$R_a = \frac{3+2+1+4+7+2}{6} \approx 3,167$$

To find RMS (R_q), average the same six numbers, add their squares together, divide by 6 and find the square root.

RMS average

$$R_q = \sqrt{\frac{9+4+1+16+49+4}{6}} \approx 3,719$$

R_q is the RMS average of the heights of all of the roughness profile points in one cut-off.

R_t = Max roughness height in five cut-offs

R_t specifies the vertical distance between the highest peak and the deepest valley in a length equal to five consecutive cut-off lengths of the roughness profile.

Mathematically

$$R_t = P_{\max} - V_{\max}$$

R_z = Ten point roughness height

R_z is one fifth the sum of the absolute values of the heights of the five highest profile peaks and the depths of the five deepest profile valleys in one cut-off length of the roughness profile.

Mathematically:

$$R_z = \frac{h_1+h_2+h_3+h_4+h_5}{5}$$

R_y = Max roughness height, one cut-off

R_y (called R_{\max} until 1981) is the vertical distance between the top of the highest peak and the bottom of the deepest valley in one sampling length of the roughness profile.

Mathematically

$$R_y = P_1 - V_1$$

R_{tm} = Mean R_t

R_{tm} is not “mean R_t ” at all: it is a mean R_y specification. It is the arithmetic average of five R_y in five consecutive cut-offs.

Mathematically

$$R_{tm} = \frac{R_{y1}+R_{y2}+R_{y3}+R_{y4}+R_{y5}}{5}$$

PC = Peak count

Peak count bears a close family resemblance to high spot count. In PC a “trigger zone” – a specifiable and selectable “dead band” – is established symmetrically about the mean line of the roughness profile and the instrument counts full-wave excursions of the profile through this zone for one inch along the nominal profile. The result is called “peaks per inch”.

A = Cut-off length

Cut-off length is generally the same as sample length. The cut-off length is the distance used to determine roughness center-line. Variations over longer distances are defined as waviness.

R_{sk} = Skewness or Symmetry definition

Mean line: the straight line in the general direction of the profile that divides the profile so as to close equal areas above and below the mean line. By the convention to be followed here, this mean line will serve as the x-axis of the coordinate system we will use to help define profile features and will think of as being horizontal, whether the surface from which we got the peak and valley lines really happened to be horizontal or not.

Sample length: the distance in the direction of the nominal profile (along the mean line or the x-axis of our coordinate system) that is the greatest allowable distance between surface peaks and valleys we will agree to call roughness. Unless specified otherwise, this will be 0.030 in. (0,762 mm). Any surface irregularities spaced farther apart than one sampling length will be called either waviness or deviations in geometric form.

Surface textures

Lay: The direction of the predominant surface pattern; determined by the production method.

Flaws: Random irregularities such as scratches, holes, cracks, peaks and ridges.

Waviness: Irregularities on a surface in the form of waves. On smooth machined surfaces, such waves measure 0.030 to 1 in. long or more.

Roughness: Irregularities on a surface more closely spaced than waviness. Roughness may be superimposed on a wavy surface. On smooth machined surfaces, the peak separation distance is usually between 0.0002 and 0.030 in. The height of these irregularities is much less than their width, usually between 0.000001 and 0.0005 in.

Characteristics and description

Shaft diameter: The physical outside diameter (O.D.) with appropriate tolerance.

Hardness: Preferably measured in Rockwell C units. Recommended hardness is Rockwell C45 minimum for typical applications.

Roundness: The O.D. profile measured in millionths of an inch and compared to a true circle.

Surface roughness: Surface irregularities produced by the cutting or abrading action of machine tools measured axially and circumferentially. A roughness of 0,25 to 0,50 $R_a \mu\text{m}$ (10 to 20 $R_a \mu\text{in.}$) is recommended.

Surface lay: The direction of the predominant surface pattern produced by tool marks or grain of the surface. Ordinarily dependent upon the production method used.

Machine lead: A microscopic screw thread on the shaft O.D. resulting from the finishing operation. Can be either right or left hand. It is recommended that the shaft surface have a machine lead of zero with a tolerance of $\pm 0,05^\circ$ ($\pm 3'$) of lead angle.

General condition: Presence of pit flaws, impurities, nicks, burrs, cracks, etc.

SKF Polyseal recommendations for reciprocating cylinder rods

Low pressure hydraulic and pneumatic applications

$$R_a = 0,16 \text{ to } 4,47 \mu\text{m} \text{ (4 to 12 } \mu\text{in.)}$$

$$R_{sk} = -0,04 \text{ to } -0,16 \text{ (-1.0 to -4.0)}$$

$$R_z \leq 1,97 \mu\text{m} \text{ (50 } \mu\text{in.)}$$

High pressure hydraulic and high pressure gas applications

$$R_a = 0,04 \text{ to } 0,16 \mu\text{m} \text{ (1 to 4 } \mu\text{in.)}$$

$$R_{sk} = 0,00 \text{ to } -0,12 \text{ (0.0 to -3.0)}$$

$$R_z \leq 1,18 \mu\text{m} \text{ (30 } \mu\text{in.)}$$

Recommended for cylinder bore and slow rotary rod applications

Low pressure hydraulic and pneumatic applications

$$R_a = 0,16 \text{ to } 0,79 \text{ (4 to 20 } \mu\text{in.)}$$

$$R_{sk} = -0,04 \text{ to } -0,16 \text{ (-1.0 to -4.0)}$$

$$R_z \leq 3,15 \mu\text{m} \text{ (80 } \mu\text{in.)}$$

Recommended for Spectraseal finish requirements

Media sealed	Static surface	Dynamic surface
Cryogenic and critical sealing of light gasses	$R_a = 0,24 \text{ to } 0,47 \mu\text{m} \text{ (6 to 12 } \mu\text{in.)}$ $R_z < 1,97 \mu\text{m} \text{ (50 } \mu\text{in.)}$ $R_{sk} = -0,04 \text{ to } -0,16 \text{ (-1.0 to -4.0)}$	$R_a = 0,08 \text{ to } 0,31 \mu\text{m} \text{ (2 to 8 } \mu\text{in.)}$ $R_z < 1,18 \mu\text{m} \text{ (30 } \mu\text{in.)}$ $R_{sk} = -0,04 \text{ to } -0,16 \text{ (-1.0 to -4.0)}$
Less critical gas sealing	$R_a = 0,63 \text{ to } 1,26 \text{ (16-32 } \mu\text{in.)}$ $R_z < 3,15 \mu\text{m} \text{ (80 } \mu\text{in.)}$ $R_{sk} = -0,04 \text{ to } -0,16 \text{ (-1.0 to -4.0)}$	$R_a = 0,24 \text{ to } 0,47 \mu\text{m} \text{ (6 to 12 } \mu\text{in.)}$ $R_z < 1,97 \mu\text{m} \text{ (50 } \mu\text{in.)}$ $R_{sk} = -0,04 \text{ to } -0,16 \text{ (-1.0 to -4.0)}$
Fluid sealing	$R_a = 0,63 \text{ to } 1,26 \text{ (20 to 63 } \mu\text{in.)}$ $R_z < 3,15 \mu\text{m} \text{ (80 } \mu\text{in.)}$ $R_{sk} = -0,04 \text{ to } -0,016 \text{ (-1.0 to -4.0)}$	$R_a = 0,24 \text{ to } 0,47 \mu\text{m} \text{ (8-16 } \mu\text{in.)}$ $R_z < 1,97 \mu\text{m} \text{ (50 } \mu\text{in.)}$ $R_{sk} = -0,04 \text{ to } -0,16 \text{ (-1.0 to -4.0)}$

Storage recommendations

Finished product items must be protected from ozone, especially in the presence of ultraviolet light, moisture, high temperature (not exceeding 52 °C (125 °F), swelling agents (fuel and other solvents), corrosive vapors and mechanical stress which modify the network structure of the elastomeric components of the item and may modify the reinforcing action of the fillers.

Shelf life of finished products

5 years

Polyurethane molded products
Hytrel* molded products
Nylon molded products

15 years

Nitrile products
Carboxylated products
HNBR products

No limit

PTFE products
UHMW products
Fluorocarbon rubber FKM products
EPR products

* Hytrel™ is a registered trademark of DuPont.

Rod seals

Polyurethane U Cups and rod seals

Part numbers for U Cups and rod seals

Metric example

Metric -sized rod seals are designated by MPS at the start of the part number followed by inside diameter, outside diameter, height and then rod seal type.

MPS-016-024-05,8 DZ

MPS-016-024-05,8 UBR

Inch example

Inch-sized rod seals are designated by cross section, seal inside diameter, height and then rod seal type.

125-01.125-250-DZ

UBR-125-01.250-250

Product tables

See **page 18** for metric-sized and **page 20** for inch-sized products.



UBR / ZBR



Deep Z Seal

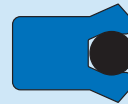

Poly O

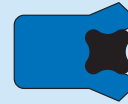

Type B

Operational range

UBR/ZBR seal

Pressure: 400 bar (5 800 psi)
 Temperature: -40 to +120 °C (-40 to +248 °F)
 Max. velocity: 1,0 m/s (3 ft./s)
 Surface finish: R_a 0,1 to 0,4 µm (4 to 16 µin.)

Type B

Pressure: 400 bar (5 800 psi)
 Temperature: -40 to +120 °C (-40 to +248 °F)
 Max. velocity: 1,0 m/s (3 ft./s)
 Surface finish: R_a 0,1 to 0,4 µm (4 to 16 µin.)

Deep Z-Seal

Pressure: 400 bar (5 800 psi)
 Temperature: -40 to +120 °C (-40 to +248 °F)
 Max velocity: 1,0 m/s (3 ft./s)
 Surface finish: R_a 0,1 to 0,4 µm (4 to 16 µin.)

Deep Z with delta anti-extrusion ring

Pressure: 400 bar (5 800 psi)
 Temperature: -54 to +105 °C (-65 to +221 °F)
 Max velocity: 1,0 m/s (3 ft./s)
 Surface finish: R_a 0,1 to 0,4 µm (4 to 16 µin.)

Recommended material

U-1023 HP Lubrithane
 U-1029 HP Lubrithane
 U-1027 EXHP Lubrithane

U-1003 Lubrithane 100 °C (212 °F)
 U-1023 HP Lubrithane
 U-1029 HP Lubrithane
 F-1504 Fluorotrel

U-1003 Lubrithane 100 °C (212 °F)
 U-1023 HP Lubrithane
 U-1029 HP Lubrithane
 F-1504 Fluorotrel

A-8504 Low-temp nitrile lip
 U-1003 Lubrithane base 100 °C (212 °F)
 F-1504 Fluorotrel
 P-2506 Nylon

Extrusion gap

Pressure

70 °C (158 °F)

90 °C (194 °F)

mm (in.)

bar (psi)

bar (psi)

Extrusion gaps U-1003

0,25 (0.10)	345 (5 000)	275 (4 000)
3,81 (0.15)	345 (5 000)	225 (3 300)
5,08 (0.20)	310 (4 500)	170 (2 500)

Extrusion gaps U-1003/Nylon

0,25 (0.10)	690 (10 000)	690 (10 000)
3,81 (0.15)	690 (10 000)	690 (10 000)
5,08 (0.20)	690 (10 000)	690 (10 000)

Pressure w/wear guides U-1003/Nylon

6,35 (0.25)	690 (10 000)	490 (7 000)
12,70 (0.50)	410 (6 000)	300 (4 400)
19,05 (0.75)	300 (4 400)	250 (3 600)

Installation guide

Cross section vs. diameter

Cross section	Minimum diameter rod seal		Minimum diameter piston seal	
	Polyurethane (PU) Rod seal d	Polyether-ester (PE) Rod seal (Hytrel/Fluorotrel) d	Polyurethane (PU) Piston seal D	Polyether-ester (PE) Piston seal (Hytrel/Fluorotrel) D
in				
0.125	0.750 I.D.	1.000 I.D.	1.250 O.D.	1.750 O.D.
0.187	1.000 I.D.	1.750 I.D.	1.750 O.D.	2.750 O.D.
0.250	1.750 I.D.	2.750 I.D.	3.000 O.D.	4.500 O.D.
0.375	3.000 I.D.	5.000 I.D.	6.000 O.D.	8.000 O.D.
0.500	6.000 I.D.	8.000 I.D.	10.000 O.D.	12.000 O.D.
0.750	8.000 I.D.	9.000 I.D.	15.000 O.D.	17.000 O.D.
1.000	10.000 I.D.	10.000 I.D.	20.000 O.D.	25.000 O.D.

Customizing formula

The following formula may be used when altering the application data for custom applications. This formula will maintain the proper cross-section relationship required for effective sealing.

Oversize bores

To calculate groove diameter to fit the oversize bore and seal cross-section, the following formula is used:

$$D_1 = B_1 - (B - D)$$

Where

- D_1 = New groove diameter to correspond with B_1
- B_1 = Oversize bore diameter
- B = Next smaller standard bore diameter listed
- D = Standard groove diameter to correspond with B for maximum extrusion gap dimensions

To calculate groove depth

$$\text{Groove depth} = \frac{P_1 - D_1}{2}$$

where

P_1 = Piston O.D.

The tolerance shown will still apply

Undersize rods

To calculate groove diameter to fit the undersized rod and seal cross-section, the following formula is used:

$$G_1 = E_1 + (G - E)$$

Where

- G_1 = Groove diameter to correspond with E_1
- E_1 = Undersize rod diameter
- G = Standard groove diameter to correspond with E for maximum extrusion gap dimension
- E = Next largest standard rod diameter listed

To calculate groove depth

$$\text{Groove depth} = \frac{G_1 - H_1}{2}$$

where

H_1 = Housing bore diameter

The tolerance shown will still apply

Polyurethane U cups and rod seals – metric sizes

d₁ 16 – 250 mm

b₁ = 2,0 mm

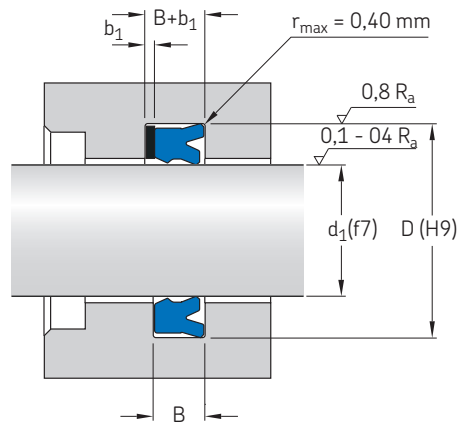
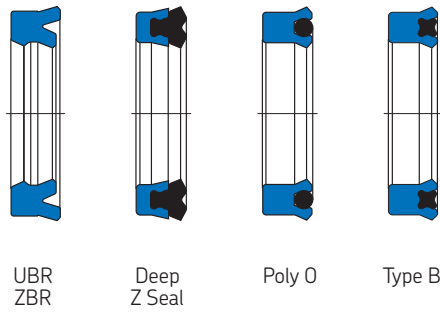

Dimensions

Designation*

d ₁	D	B	B+b ₁	Designation*
mm				–
16	24	6,8	8,8	MPS-016-024-05,8 *
18	26	6,0	8,0	MPS-018-026-05,0 *
20	26	6,5	8,5	MPS-020-026-05,5 *
20	28	6,0	8,0	MPS-020-028-05,0 *
20	30	8,0	8,0	MPS-020-030-07,0 *
22	30	6,0	8,0	MPS-022-030-05,0 *
25	33	6,0	8,0	MPS-025-033-05,0 *
25	35	6,0	10,3	MPS-025-035-05,0 *
25	35	9,0	11,0	MPS-025-035-08,0 *
30	40	7,0	9,0	MPS-030-040-06,0 *
30	45	11,0	13,0	MPS-030-045-10,0 *
35	45	7,0	9,0	MPS-035-045-06,0 *
35	45	11,0	13,0	MPS-035-045-10,0 *
35	50	11,0	13,0	MPS-035-050-10,0 *
36	46	9,0	11,0	MPS-036-046-08,0 *
40	50	7,0	9,0	MPS-040-050-06,0 *
40	50	9,0	11,0	MPS-040-050-08,0 *
40	55	11,0	13,0	MPS-040-055-10,0 *
45	55	7,0	9,0	MPS-045-055-06,0 *
45	55	11,0	13,0	MPS-045-055-10,0 *
45	60	11,0	13,0	MPS-045-060-10,0 *
50	60	7,0	9,0	MPS-036-046-08,0 *
50	60	8,3	10,3	MPS-036-046-08,0 *
50	60	11,0	13,0	MPS-050-060-10,0 *
50	60	13,0	15,0	MPS-050-060-12,0 *
50	63	10,0	12,0	MPS-050-063-09,0 *
50	65	10,0	12,0	MPS-050-065-09,0 *
50	65	11,0	13,0	MPS-050-065-10,0 *
53	63	7,0	9,0	MPS-053-063-06,0 *
55	65	7,0	9,0	MPS-055-065-06,0 *
55	70	10,0	12,0	MPS-055-070-09,0 *
55	75	13,0	15,0	MPS-055-075-12,0 *
60	70	7,0	9,0	MPS-060-070-06,0 *
60	70	8,5	10,5	MPS-060-070-07,5 *
60	70	10,0	12,0	MPS-060-070-09,0 *
60	70	13,0	15,0	MPS-060-070-12,0 *

* Designate rod seal or U cups by ZBR, DZ, B, DP, Z, PO, BPO, UBR, UNR, US

Dimensions				Designation*
d ₁	D	B	B+b ₁	
mm				–
60	75	11,0	13,0	MPS-060-075-10,0 *
60	76	11,0	13,0	MPS-060-076-10,0 *
60	80	13,0	15,0	MPS-060-080-12,0 *
63	73	13,0	15,0	MPS-063-073-12,0 *
65	75	7,0	9,0	MPS-065-075-06,0 *
65	75	13,0	15,0	MPS-065-075-12,0 *
65	80	11,0	13,0	MPS-065-080-10,0 *
65	85	13,0	15,0	MPS-065-085-12,0 *
70	80	7,0	9,0	MPS-070-080-06,0 *
70	80	13,0	15,0	MPS-070-080-12,0 *
70	84	14,0	16,0	MPS-070-084-13,0 *
70	85	11,0	13,0	MPS-070-085-10,0 *
70	90	13,0	15,0	MPS-070-090-12,0 *
75	85	7,0	9,0	MPS-075-085-06,0 *
75	90	11,0	13,0	MPS-075-090-10,0 *
75	91	11,0	13,0	MPS-075-091-10,0 *
75	95	13,0	15,0	MPS-075-095-12,0 *
80	90	7,0	9,0	MPS-080-090-06,0 *
80	95	12,4	14,4	MPS-080-095-11,4 *
80	95	13,5	15,5	MPS-080-095-12,5 *
80	100	13,0	15,0	MPS-080-100-12,0 *
85	100	10,0	12,0	MPS-085-100-09,0 *
85	105	13,0	15,0	MPS-085-105-12,0 *
90	105	10,0	12,0	MPS-090-105-09,0 *
90	110	13,0	15,0	MPS-090-110-12,0 *
95	110	11,0	13,0	MPS-095-110-10,0 *
95	115	13,0	15,0	MPS-095-115-12,0 *
100	115	10,0	12,0	MPS-100-115-09,0 *
100	120	13,0	15,0	MPS-100-120-12,0 *
105	120	11,0	13,0	MPS-105-120-10,0 *
105	125	16,0	18,0	MPS-105-125-15,0 *
110	125	11,0	13,0	MPS-110-125-10,0 *
110	130	11,0	13,0	MPS-110-130-10,0 *
112	125	10,0	12,0	MPS-112-125-09,0 *
120	140	16,0	18,0	MPS-120-140-15,0 *
125	140	10,0	12,0	MPS-125-140-09,0 *
125	145	16,0	18,0	MPS-125-145-15,0 *
130	145	11,0	13,0	MPS-130-145-10,0 *
130	150	16,0	18,0	MPS-130-150-15,0 *
136	150	10,0	12,0	MPS-136-150-09,0 *
140	155	10,0	12,0	MPS-140-155-09,0 *
140	160	16,0	18,0	MPS-140-160-15,0 *
145	160	10,0	11,0	MPS-145-160-09,0 *
150	170	16,0	18,0	MPS-150-170-15,0 *
155	180	18,0	20,0	MPS-155-180-16,0 *
165	180	10,5	12,5	MPS-165-180-09,5 *
180	200	13,5	15,5	MPS-180-200-12,5 *
180	205	18,0	21,0	MPS-180-205-16,0 *
200	220	13,5	15,5	MPS-200-220-12,5 *
225	250	21,0	23,0	MPS-225-250-19,0 *
230	250	13,5	15,5	MPS-230-250-12,5 *
250	275	21,0	23,0	MPS-250-275-19,0 *

* Designate rod seal or U cups by ZBR, DZ, B, DP, Z, PO, BPO, UBR, UNR, US

Polyurethane U cups and rod seals – inch sizes

c 0.125-0.187 in.

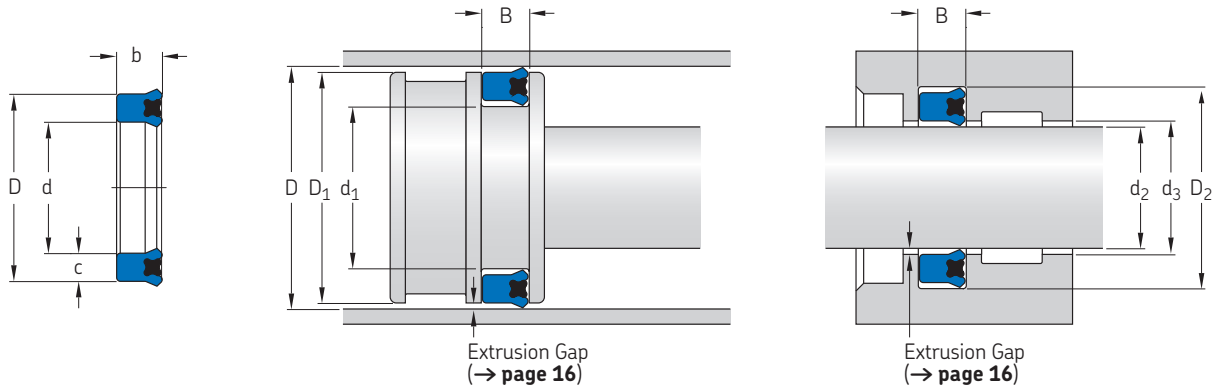

Cross section width c	Nominal dimensions			Dimensions			Rod application			Part number	
	Rod diameter d	Gland diameter D	Depth b	Groove length B	Piston application Bore D	Piston D ₁	Groove d ₁	Rod d ₂	Throat d ₃		Groove D ₂
in.	in.			in.	in.			in.			–
0.125	1.000	1.250	0.125	0.138	1.250	1.249	1.000	1.000	1.001	1.250	125-01.000
			0.250	0.275							125-01.000-250
	1.062	1.312	0.125	0.138	1.312	1.311	1.062	1.062	1.063	1.312	125-01.062
			0.250	0.275							125-01.062-250
	1.125	1.375	0.125	0.138	1.375	1.374	1.125	1.125	1.126	1.375	125-01.125
			0.250	0.275							125-01.125-250
	1.187	1.437	0.125	0.138	1.437	1.436	1.187	1.187	1.188	1.437	125-01.187
			0.250	0.275							125-01.187-250
	1.250	1.500	0.125	0.138	1.500	1.499	1.250	1.250	1.251	1.500	125-01.250
			0.250	0.275							125-01.250-250
	1.312	1.562	0.125	0.138	1.562	1.561	1.312	1.312	1.313	1.562	125-01.312
			0.250	0.275							125-01.312-250
1.375	1.625	0.125	0.138	1.625	1.624	1.375	1.375	1.376	1.625	125-01.375	
		0.250	0.275							125-01.375-250	
1.437	1.687	0.125	0.138	1.687	1.686	1.437	1.437	1.438	1.687	125-01.437	
		0.250	0.275							125-01.437-250	
1.500	1.750	0.125	0.138	1.750	1.749	1.500	1.500	1.501	1.750	125-01.500	
		0.250	0.275							125-01.500-250	

Cross section width c	Nominal dimensions			Dimensions			Rod application			Part number	
	Rod diameter d	Gland diameter D	Depth b	Groove depth B +0.010/-0	Piston application		Groove d ₁ +0/-0.002	Rod d ₂ +0/-0.002	Throat d ₃ +0.002/-0		Groove D ₂ +0.002/-0
in.	in.			in.	in.		in.			-	
0.187	1.000	1.375	0.187 0.312	0.207 0.344	1.375	1.374	1.000	1.000	1.001	1.375	187-01.000 187-01.000-312
	1.062	1.437	0.187 0.312	0.207 0.344	1.437	1.436	1.062	1.062	1.063	1.437	187-01.062 187-01.062-312
	1.125	1.500	0.187 0.312	0.207 0.344	1.500	1.499	1.125	1.125	1.126	1.500	187-01.125 187-01.125-312
	1.187	1.562	0.187 0.312	0.207 0.344	1.562	1.561	1.187	1.187	1.188	1.562	187-01.187 187-01.187-312
	1.250	1.625	0.187 0.312	0.207 0.344	1.625	1.624	1.250	1.250	1.251	1.625	187-01.250 187-01.250-312
	1.312	1.687	0.187 0.312	0.207 0.344	1.687	1.686	1.312	1.312	1.313	1.687	187-01.312 187-01.312-312
	1.375	1.750	0.187 0.312	0.207 0.344	1.750	1.749	1.375	1.375	1.376	1.750	187-01.375 187-01.375-312
	1.437	1.812	0.187 0.312	0.207 0.344	1.812	1.811	1.437	1.437	1.438	1.812	187-01.437 187-01.437-312
	1.500	1.875	0.187 0.375	0.207 0.413	1.875	1.874	1.500	1.500	1.501	1.875	187-01.500 187-01.500-375
	1.625	2.000	0.187 0.375	0.207 0.413	2.000	1.999	1.625	1.625	1.626	2.000	187-01.625 187-01.625-375
	1.687	2.062	0.187 0.375	0.207 0.413	2.062	2.061	1.687	1.687	1.688	2.062	187-01.687 187-01.687-375
	1.750	2.125	0.187 0.375	0.207 0.413	2.125	2.124	1.750	1.750	1.751	2.125	187-01.750 187-01.750-375
	1.875	2.250	0.187 0.375	0.207 0.413	2.250	2.249	1.875	1.875	1.876	2.250	187-01.875 187-01.875-375
	2.000	2.375	0.187 0.375	0.207 0.413	2.375	2.374	2.000	2.000	2.001	2.375	187-02.000 187-02.000-375
	2.125	2.500	0.187 0.375	0.207 0.413	2.500	2.499	2.125	2.125	2.126	2.500	187-02.125 187-02.125-375
	2.250	2.625	0.187 0.375	0.207 0.413	2.625	2.624	2.250	2.250	2.251	2.625	187-02.250 187-02.250-375
	2.375	2.750	0.187 0.375	0.207 0.413	2.750	2.749	2.375	2.375	2.376	2.750	187-02.375 187-02.375-375
	2.500	2.875	0.187 0.375	0.207 0.413	2.875	2.874	2.500	2.500	2.501	2.875	187-02.500 187-02.500-375
	2.625	3.000	0.187 0.375	0.207 0.413	3.000	2.999	2.625	2.625	2.626	3.000	187-02.625 187-02.625-375
	2.750	3.125	0.187 0.375	0.207 0.413	3.125	3.124	2.750	2.750	2.751	3.125	187-02.750 187-02.750-375
	2.875	3.250	0.187 0.375	0.207 0.413	3.250	3.249	2.875	2.875	2.876	3.250	187-02.875 187-02.875-375
	3.000	3.375	0.187 0.375	0.207 0.413	3.375	3.374	3.000	3.000	3.001	3.375	187-03.000 187-03.000-375

Polyurethane U cups and rod seals – inch sizes

c 0.250-0.312 in.

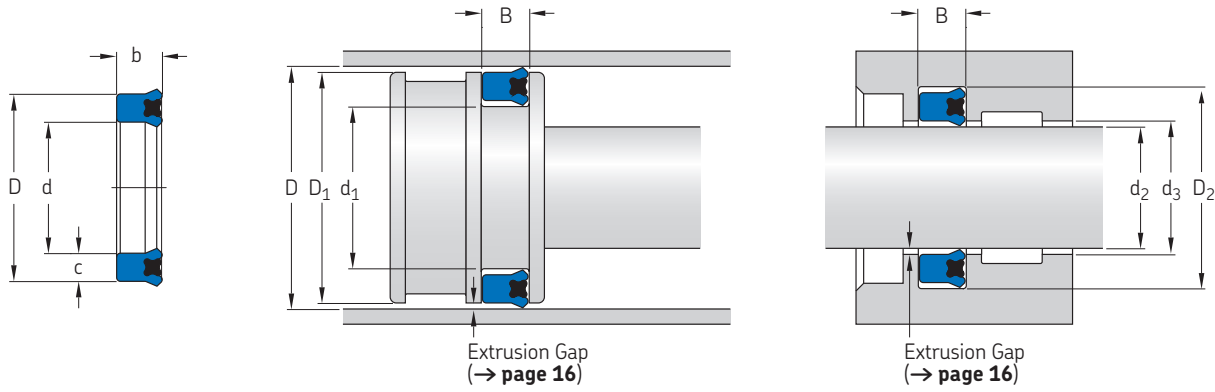

Cross section width c	Nominal dimensions			Dimensions				Rod application			Part number
	Rod diameter d	Gland diameter D	Depth b	Groove depth B	Piston application		Groove d ₁	Rod d ₂	Throat d ₃	Groove D ₂	
				+0.010/-0	Bore D	Piston D ₁	+0/-0.003	+0/-0.002	+0.003/-0	+0.003/-0	
in.	in.			in.	in.			in.			-
0.250	1.750	2.250	0.250	0.275	2.250	2.249	1.750	1.750	1.751	2.250	250-01.750
			0.375	0.413							250-01.750-375
	1.875	2.375	0.250	0.275	2.375	2.374	1.875	1.875	1.876	2.375	250-01.875
			0.375	0.413							250-01.875-375
	2.000	2.500	0.250	0.275	2.500	2.499	2.000	2.000	2.001	2.500	250-02.000
			0.375	0.413							250-02.000-375
	2.125	2.625	0.250	0.275	2.625	2.624	2.125	2.125	2.126	2.625	250-02.125
			0.375	0.413							250-02.125-375
	2.250	2.750	0.250	0.275	2.750	2.749	2.250	2.250	2.251	2.750	250-02.250
			0.375	0.413							250-02.250-375
	2.375	2.875	0.250	0.275	2.875	2.874	2.375	2.375	2.376	2.875	250-02.375
			0.375	0.413							250-02.375-375
	2.500	3.000	0.250	0.275	3.000	2.999	2.500	2.500	2.501	3.000	250-02.500
			0.375	0.413							250-02.500-375
	2.625	3.125	0.250	0.275	3.125	3.124	2.625	2.625	2.626	3.125	250-02.625
			0.375	0.413							250-02.625-375
	2.750	3.250	0.250	0.275	3.250	3.249	2.750	2.750	2.751	3.250	250-02.750
			0.375	0.413							250-02.750-375
	2.875	3.375	0.250	0.275	3.375	3.374	2.875	2.875	2.876	3.375	250-02.875
			0.375	0.413							250-02.875-375
	3.000	3.500	0.250	0.275	3.500	3.499	3.000	3.000	3.001	3.500	250-03.000
			0.375	0.413							250-03.000-375
	3.125	3.625	0.250	0.275	3.625	3.624	3.125	3.125	3.126	3.625	250-03.125
			0.375	0.413							250-03.125-375
	3.250	3.750	0.250	0.275	3.750	3.749	3.250	3.250	3.251	3.750	250-03.250
			0.375	0.413							250-03.250-375
	3.375	3.875	0.250	0.275	3.875	3.874	3.375	3.375	3.376	3.875	250-03.375
			0.375	0.413							250-03.375-375
	3.500	4.000	0.250	0.275	4.000	3.999	3.500	3.500	3.501	4.000	250-03.500
			0.375	0.413							250-03.500-375
3.625	4.125	0.250	0.275	4.125	4.124	3.625	3.625	3.626	4.125	250-03.625	
		0.375	0.413							250-03.625-375	
3.750	4.250	0.250	0.275	4.250	4.249	3.750	3.750	3.751	4.250	250-03.750	
		0.375	0.413							250-03.750-375	
4.000	4.500	0.250	0.275	4.500	4.499	4.000	4.000	4.001	4.500	250-04.000	
		0.562	0.619							250-04.000-562	
4.125	4.625	0.250	0.275	4.625	4.624	4.125	4.125	4.126	4.625	250-04.125	
		0.562	0.619							250-04.125-562	
4.250	4.750	0.250	0.275	4.750	4.749	4.250	4.250	4.251	4.750	250-04.250	
		0.562	0.619							250-04.250-562	
4.375	4.875	0.250	0.275	4.875	4.874	4.375	4.375	4.376	4.875	250-04.375	
		0.562	0.619							250-04.375-562	
4.500	5.000	0.250	0.275	5.000	4.999	4.500	4.500	4.501	5.000	250-04.500	
		0.562	0.619							250-04.500-562	
4.625	5.125	0.250	0.275	5.125	5.124	4.625	4.625	4.626	5.125	250-04.625	
		0.562	0.619							250-04.625-562	
4.750	5.250	0.250	0.275	5.250	5.249	4.750	4.750	4.751	5.250	250-04.750	
		0.562	0.619							250-04.750-562	
4.875	5.375	0.250	0.275	5.375	5.374	4.875	4.875	4.876	5.375	250-04.875	
		0.562	0.619							250-04.875-562	
5.000	5.500	0.250	0.275	5.500	5.499	5.000	5.000	5.001	5.500	250-05.000	
		0.562	0.619							250-05.000-562	

Cross section width c	Nominal dimensions			Dimensions			Rod application			Part number	
	Rod diameter d	Gland diameter D	Depth b	Groove depth B +0.010/-0	Piston application Bore D +0.003/-0 Piston D ₁ +0/-0.002		Groove d ₁ +0/-0.004	Rod d ₂ +0/-0.002	Throat d ₃ +0.003/-0		Groove D ₂ +0.004/-0
in.	in.		in.	in.			in.			-	
0.312	2.250	2.875	0.312 0.500	0.344 0.550	2.875	2.873	2.250	2.250	2.252	2.875	312-02.250 312-02.250-500
	2.375	3.000	0.312 0.500	0.344 0.550	3.000	2.998	2.375	2.375	2.377	3.000	312-02.375 312-02.375-500
	2.500	3.125	0.312 0.500	0.344 0.550	3.125	3.123	2.500	2.500	2.502	3.125	312-02.500 312-02.500-500
	2.625	3.250	0.312 0.500	0.344 0.550	3.250	3.248	2.625	2.625	2.627	3.250	312-02.625 312-02.625-500
	2.750	3.375	0.312 0.500	0.344 0.550	3.375	3.373	2.750	2.750	2.752	3.375	312-02.750 312-02.750-500
	2.875	3.500	0.312 0.500	0.344 0.550	3.500	3.498	2.875	2.875	2.877	3.500	312-02.875 312-02.875-500
	3.000	3.625	0.312 0.500	0.344 0.550	3.625	3.623	3.000	3.000	3.002	3.625	312-03.000 312-03.000-500
	3.125	3.750	0.312 0.500	0.344 0.550	3.750	3.748	3.125	3.125	3.127	3.750	312-03.125 312-03.125-500
	3.250	3.875	0.312 0.500	0.344 0.550	3.875	3.873	3.250	3.250	3.252	3.875	312-03.250 312-03.250-500
	3.375	4.000	0.312 0.500	0.344 0.550	4.000	3.998	3.375	3.375	3.377	4.000	312-03.375 312-03.375-500
	3.500	4.125	0.312 0.500	0.344 0.550	4.125	4.123	3.500	3.500	3.502	4.125	312-03.500 312-03.500-500
	3.625	4.250	0.312 0.500	0.344 0.550	4.250	4.248	3.625	3.625	3.627	4.250	312-03.625 312-03.625-500
	3.750	4.375	0.312 0.500	0.344 0.550	4.375	4.373	3.750	3.750	3.752	4.375	312-03.750 312-03.750-500
	3.875	4.500	0.312 0.562	0.344 0.619	4.500	4.498	3.875	3.875	3.877	4.500	312-03.875 312-03.875-500
	4.000	4.625	0.312 0.562	0.344 0.619	4.625	4.623	4.000	4.000	4.002	4.625	312-04.000 312-04.000-562
	4.125	4.750	0.312 0.562	0.344 0.619	4.750	4.748	4.125	4.125	4.127	4.750	312-04.125 312-04.125-562
	4.250	4.875	0.312 0.562	0.344 0.619	4.875	4.873	4.250	4.250	4.252	4.875	312-04.250 312-04.250-562
	4.375	5.000	0.312 0.562	0.344 0.619	5.000	4.998	4.375	4.375	4.377	5.000	312-04.375 312-04.375-562
	4.500	5.125	0.312 0.625	0.344 0.688	5.125	5.123	4.500	4.500	4.502	5.125	312-04.500 312-04.500-625
	4.625	5.250	0.312 0.625	0.344 0.688	5.250	5.248	4.625	4.625	4.627	5.250	312-04.625 312-04.625-625
	4.750	5.375	0.312 0.625	0.344 0.688	5.375	5.373	4.750	4.750	4.752	5.375	312-04.750 312-04.750-625
	4.875	5.500	0.312 0.625	0.344 0.688	5.500	5.498	4.875	4.875	4.877	5.500	312-04.875 312-04.875-625
	5.000	5.625	0.312 0.625	0.344 0.688	5.625	5.623	5.000	5.000	5.002	5.625	312-05.000 312-05.000-625
	5.125	5.750	0.312 0.625	0.344 0.688	5.750	5.748	5.125	5.125	5.127	5.750	312-05.125 312-05.125-625
	5.250	5.875	0.312 0.625	0.344 0.688	5.875	5.873	5.250	5.250	5.252	5.875	312-05.250 312-05.250-625
	5.375	6.000	0.312 0.625	0.344 0.688	6.000	5.998	5.375	5.375	5.377	6.000	312-05.375 312-05.375-625
	5.500	5.125	0.312 0.625	0.344 0.688	6.125	6.123	5.500	5.500	5.502	6.125	312-05.500 312-05.500-625
	5.625	6.250	0.312 0.625	0.344 0.688	6.250	6.248	5.625	5.625	5.627	6.250	312-05.625 312-05.625-625
	5.750	6.375	0.312 0.625	0.344 0.688	6.375	6.373	5.750	5.750	5.752	6.375	312-05.750 312-05.750-625
	5.875	6.500	0.312 0.625	0.344 0.688	6.500	6.498	5.875	5.875	5.877	6.500	312-05.875 312-05.875-625
	6.000	6.625	0.312 0.625	0.344 0.688	6.625	6.623	6.000	6.000	6.002	6.625	312-06.000 312-06.000-625
	6.125	6.750	0.312 0.625	0.344 0.688	6.750	6.748	6.125	6.125	6.127	6.750	312-06.125 312-06.125-625
6.250	6.875	0.312 0.625	0.344 0.688	6.875	6.873	6.250	6.250	6.252	6.875	312-06.250 312-06.250-625	
6.375	7.000	0.312 0.625	0.344 0.688	7.000	6.998	6.375	6.375	6.377	7.000	312-06.375 312-06.375-625	
6.500	7.125	0.312 0.625	0.344 0.688	7.125	7.123	6.500	6.500	6.502	7.125	312-06.500 312-06.500-625	

Polyurethane U cups and rod seals – inch sizes

c 0.375 in.

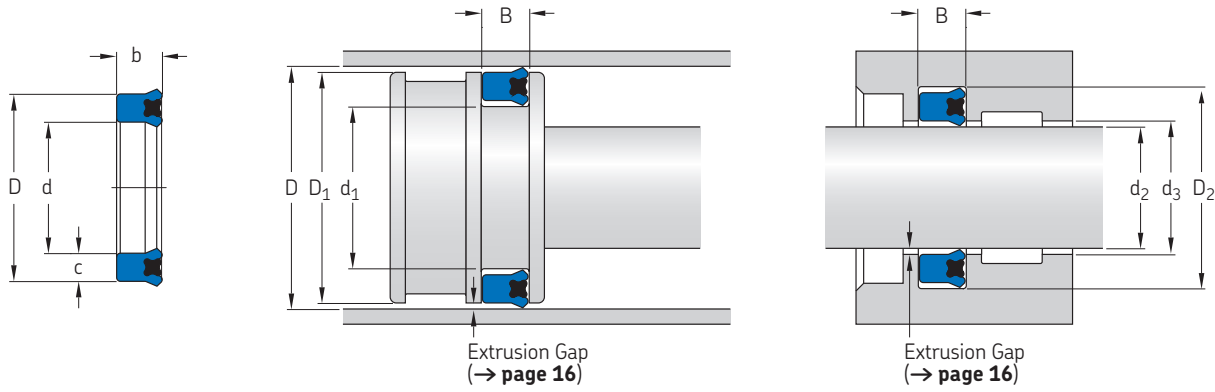

Cross section width c	Nominal dimensions			Dimensions				Rod application			Part number
	Rod diameter d	Gland diameter D	Depth b	Groove depth B	Piston application		Groove d ₁	Rod d ₂	Throat d ₃	Groove D ₂	
				+0.010/-0	Bore D	Piston D ₁	+0/-0.003	+0/-0.002	+0.004/-0	+0.005/-0	
in.	in.		in.	in.	in.		in.	in.	in.		-
0.375	3.000	3.750	0.375	0.413	3.750	3.748	3.000	3.000	3.002	3.750	375-03.000
			0.625	0.688							375-03.000-625
	3.125	3.875	0.375	0.413	3.875	3.873	3.125	3.125	3.127	3.875	375-03.125
			0.625	0.688							375-03.125-625
	3.250	4.000	0.375	0.413	4.000	3.998	3.250	3.250	3.252	4.000	375-03.250
			0.625	0.688							375-03.250-625
	3.375	4.125	0.375	0.413	4.125	4.123	3.375	3.375	3.377	4.125	375-03.375
			0.625	0.688							375-03.375-625
	3.500	4.250	0.375	0.413	4.250	4.248	3.500	3.500	3.502	4.250	375-03.500
			0.625	0.688							375-03.500-625
	3.625	4.375	0.375	0.413	4.375	4.373	3.625	3.625	3.627	4.375	375-03.625
			0.625	0.688							375-03.625-625
	3.750	4.500	0.375	0.413	4.500	4.498	3.750	3.750	3.752	4.500	375-03.750
			0.625	0.688							375-03.750-625
	3.875	4.625	0.375	0.413	4.625	4.623	3.875	3.875	3.877	4.625	375-03.875
			0.625	0.688							375-03.875-625
	4.000	4.750	0.375	0.413	4.750	4.748	4.000	4.000	4.002	4.750	375-04.000
			0.625	0.688							375-04.000-625
	4.125	4.875	0.375	0.413	4.875	4.873	4.125	4.125	4.127	4.875	375-04.125
			0.625	0.688							375-04.125-625
	4.250	5.000	0.375	0.413	5.000	4.998	4.250	4.250	4.252	5.000	375-04.250
			0.625	0.688							375-04.250-625
	4.375	5.125	0.375	0.413	5.125	5.123	4.375	4.375	4.377	5.125	375-04.375
			0.625	0.688							375-04.375-625
	4.500	5.250	0.375	0.413	5.250	5.248	4.500	4.500	4.502	5.250	375-04.500
			0.625	0.688							375-04.500-625
	4.625	5.375	0.375	0.413	5.375	5.373	4.625	4.625	4.627	5.375	375-04.625
			0.625	0.688							375-04.625-625
4.750	5.500	0.375	0.413	5.500	5.498	4.750	4.750	4.752	5.500	375-04.750	
		0.625	0.688							375-04.750-625	
4.875	5.625	0.375	0.413	5.625	5.623	4.875	4.875	4.877	5.625	375-04.875	
		0.625	0.688							375-04.875-625	
5.000	5.750	0.375	0.413	5.750	5.748	5.000	5.000	5.002	5.750	375-05.000	
		0.625	0.688							375-05.000-625	
5.125	5.875	0.375	0.413	5.875	5.873	5.125	5.125	5.127	5.875	375-05.125	
		0.625	0.688							375-05.125-625	
5.250	6.000	0.375	0.413	6.000	5.998	5.250	5.250	5.252	6.000	375-05.250	
		0.625	0.688							375-05.250-625	
5.375	6.125	0.375	0.413	6.125	6.123	5.375	5.375	5.377	6.125	375-05.375	
		0.625	0.688							375-05.375-625	
5.500	6.250	0.375	0.413	6.250	6.248	5.500	5.500	5.502	6.250	375-05.500	
		0.625	0.688							375-05.500-625	
5.625	6.375	0.375	0.413	6.375	6.373	5.625	5.625	5.627	6.375	375-05.625	
		0.625	0.688							375-05.625-625	
5.750	6.500	0.375	0.413	6.500	6.498	5.750	5.750	5.752	6.500	375-05.750	
		0.625	0.688							375-05.750-625	
5.875	6.625	0.375	0.413	6.625	6.623	5.875	5.875	5.877	6.625	375-05.875	
		0.625	0.688							375-05.875-625	
6.000	6.750	0.375	0.413	6.750	6.748	6.000	6.000	6.002	6.750	375-06.000	
		0.625	0.688							375-06.000-625	
6.250	7.000	0.375	0.413	7.000	6.998	6.250	6.250	6.252	7.000	375-06.250	

Cross section width c	Nominal dimensions			Dimensions			Rod application			Part number	
	Rod diameter d	Gland diameter D	Depth b	Groove depth B +0.010/-0	Piston application		Groove d ₁ +0/-0.003	Rod d ₂ +0/-0.002	Throat d ₃ +0.004/-0		Groove D ₂ +0.005/-0
				Bore D +0.004/-0	Piston D ₁ +0/-0.002						
in.	in.		in.	in.			in.			-	
	6.500	7.250	0.625 0.375 0.625	0.688 0.413 0.688	7.250	7.248	6.500	6.500	6.502	7.250	375-06.250-625 375-06.500
	6.750	7.500	0.375 0.625 0.688	0.413 0.688 0.413	7.500	7.498	6.750	6.750	6.752	7.500	375-06.750 375-06.750-625
	7.000	7.750	0.375 0.625 0.688	0.413 0.688 0.413	7.750	7.748	7.000	7.000	7.002	7.750	375-06.750-625 375-07.000 375-07.000-625
	7.250	8.000	0.375 0.625 0.688	0.413 0.688 0.413	8.000	7.998	7.250	7.250	7.252	8.000	375-07.250 375-07.250-625
	7.500	8.250	0.375 0.625 0.688	0.413 0.688 0.413	8.250	8.248	7.500	7.500	7.502	8.250	375-07.500 375-07.500-625
	7.750	8.500	0.375 0.625 0.688	0.413 0.688 0.413	8.500	8.498	7.750	7.750	7.752	8.500	375-07.750 375-07.750-625
	8.000	8.750	0.375 0.625 0.688	0.413 0.688 0.413	8.750	8.748	8.000	8.000	8.002	8.750	375-08.000 375-08.000-625
	8.250	9.000	0.375 0.625 0.688	0.413 0.688 0.413	9.000	8.998	8.250	8.250	8.252	9.000	375-08.250 375-08.250-625
	8.500	9.250	0.375 0.625 0.688	0.413 0.688 0.413	9.250	9.248	8.500	8.500	8.502	9.250	375-08.500 375-08.500-625
	8.750	9.500	0.375 0.625 0.688	0.413 0.688 0.413	9.500	9.498	8.750	8.750	8.752	9.500	375-08.750 375-08.750-625
	9.000	9.750	0.375 0.625 0.688	0.413 0.688 0.413	9.750	9.748	9.000	9.000	9.002	9.750	375-09.000 375-09.000-625
	9.250	10.000	0.375 0.625 0.688	0.413 0.688 0.413	10.000	9.998	9.250	9.250	9.252	10.000	375-09.250 375-09.250-625
	9.500	10.250	0.375 0.625 0.688	0.413 0.688 0.413	10.250	10.248	9.500	9.500	9.502	10.250	375-09.500 375-09.500-625
	9.750	10.500	0.375 0.625 0.688	0.413 0.688 0.413	10.500	10.498	9.750	9.750	9.752	10.500	375-09.750 375-09.750-625
	10.000	10.750	0.375 0.625 0.688	0.413 0.688 0.413	10.750	10.748	10.000	10.000	10.002	10.750	375-10.000 375-10.000-625
	10.250	11.000	0.375 0.625 0.688	0.413 0.688 0.413	11.000	10.998	10.250	10.250	10.252	11.000	375-10.250 375-10.250-625
	10.500	11.250	0.375 0.625 0.688	0.413 0.688 0.413	11.250	11.248	10.500	10.500	10.502	11.250	375-10.500 375-10.500-625
	10.750	11.500	0.375 0.625 0.688	0.413 0.688 0.413	11.500	11.498	10.750	10.750	10.752	11.500	375-10.750 375-10.750-625
	11.000	11.750	0.375 0.625 0.688	0.413 0.688 0.413	11.750	11.748	11.000	11.000	11.002	11.750	375-11.000 375-11.000-625
	11.250	12.000	0.375 0.625 0.688	0.413 0.688 0.413	12.000	11.998	11.250	11.250	11.252	12.000	375-11.250 375-11.250-625
	11.500	12.250	0.375 0.625 0.688	0.413 0.688 0.413	12.250	12.248	11.500	11.500	11.502	12.250	375-11.500 375-11.500-625
	11.750	12.500	0.375 0.625 0.688	0.413 0.688 0.413	12.500	12.498	11.750	11.750	11.752	12.500	375-11.750 375-11.750-625
	12.000	12.750	0.375 0.625 0.688	0.413 0.688 0.413	12.750	12.748	12.000	12.000	12.002	12.750	375-12.000 375-12.000-625

Polyurethane U cups and rod seals – inch sizes

c 0.500 in.

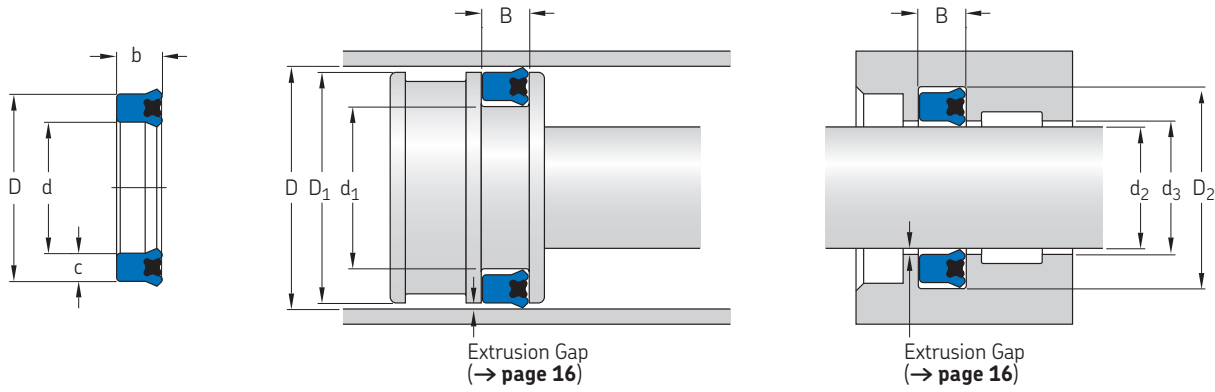

Cross section width c	Nominal dimensions			Dimensions				Rod application			Part number	
	Rod diameter d	Gland diameter D	Depth b	Groove depth B	Piston application		Groove d ₁	Rod d ₂	Throat d ₃	Groove D ₂		
				+0.010/-0	Bore D	Piston D ₁	+0/-0.003	+0/-0.007	+0/-0.003	+0.005/-0	+0.007/-0	
in.	in.		in.	in.	in.			in.				-
0.500	6.000	7.000	0.500	0.550	7.000	6.998	6.000	6.000	6.002	7.000	500-06.000	
			0.750	0.825							500-06.000-750	
	6.250	7.250	0.500	0.550	7.250	7.248	6.250	6.250	6.252	7.250	500-06.250	
			0.750	0.825								500-06.250-750
	6.500	7.500	0.500	0.550	7.500	7.498	6.500	6.500	6.502	7.500	500-06.500	
			0.750	0.825								500-06.500-750
	6.750	7.750	0.500	0.550	7.750	7.748	6.750	6.750	6.752	7.750	500-06.750	
			0.750	0.825								500-06.750-750
	7.000	8.000	0.500	0.550	8.000	7.998	7.000	7.000	7.002	8.000	500-07.000	
			0.750	0.825								500-07.000-750
	7.250	8.250	0.500	0.550	8.250	8.248	7.250	7.250	7.252	8.250	500-07.250	
			0.750	0.825								500-07.250-750
	7.500	8.500	0.500	0.550	8.500	8.498	7.500	7.500	7.502	8.500	500-07.500	
			0.750	0.825								500-07.500-750
	7.750	8.750	0.500	0.550	8.750	8.748	7.750	7.750	7.752	8.750	500-07.750	
			0.750	0.825								500-07.750-750
	8.000	9.000	0.500	0.550	9.000	8.998	8.000	8.000	8.002	9.000	500-08.000	
			0.750	0.825								500-08.000-750
	8.250	9.250	0.500	0.550	9.250	9.248	8.250	8.250	8.252	9.250	500-08.250	
			0.750	0.825								500-08.250-750
	8.500	9.500	0.500	0.550	9.500	9.498	8.500	8.500	8.502	9.500	500-08.500	
			0.750	0.825								500-08.500-750
	8.750	9.750	0.500	0.550	9.750	9.748	8.750	8.750	8.752	9.750	500-08.750	
			0.750	0.825								500-08.750-750
	9.000	10.000	0.500	0.550	10.000	9.998	9.000	9.000	9.002	10.000	500-09.000	
			0.750	0.825								500-09.000-750
	9.250	10.250	0.500	0.550	10.250	10.248	9.250	9.250	9.252	10.250	500-09.250	
			0.750	0.825								500-09.250-750
	9.500	10.500	0.500	0.550	10.500	10.498	9.500	9.500	9.502	10.500	500-09.500	
			0.750	0.825								500-09.500-750
	9.750	10.750	0.500	0.550	10.750	10.748	9.750	9.750	9.752	10.750	500-09.750	
			0.750	0.825								500-09.750-750
	10.000	11.000	0.500	0.550	11.000	10.998	10.000	10.000	10.002	11.000	500-10.000	
			0.750	0.825								500-10.000-750
	10.500	11.500	0.500	0.550	11.500	11.498	10.500	10.500	10.502	11.500	500-10.500	
			0.750	0.825								500-10.500-750
	11.000	12.000	0.500	0.550	12.000	11.998	11.000	11.000	11.002	12.000	500-11.000	
			0.750	0.825								500-11.000-750
	11.500	12.500	0.500	0.550	12.500	12.498	11.500	11.500	11.502	12.500	500-11.500	
			0.750	0.825								500-11.500-750
	12.000	13.000	0.500	0.550	13.000	12.998	12.000	12.000	12.002	13.000	500-12.000	
			0.750	0.825								500-12.000-750
	12.500	13.500	0.500	0.550	13.500	13.498	12.500	12.500	12.502	13.500	500-12.500	
			0.750	0.825								500-12.500-750
	13.000	14.000	0.500	0.550	14.000	13.998	13.000	13.000	13.002	14.000	500-13.000	
			0.750	0.825								500-13.000-750
	13.500	14.500	0.500	0.550	14.500	14.498	13.500	13.500	13.502	14.500	500-13.500	
			0.750	0.825								500-13.500-750
14.000	15.000	0.500	0.550	15.000	14.998	14.000	14.000	14.002	15.000	500-14.000		
		0.750	0.825								500-14.000-750	
14.500	15.500	0.500	0.550	15.500	15.498	14.500	14.500	14.502	15.500	500-14.500		
		0.750	0.825								500-14.500-750	
15.000	16.000	0.500	0.550	16.000	15.998	15.000	15.000	15.002	16.000	500-15.000		
		0.750	0.825								500-15.000-750	

Buffer seals

Part number descriptions

Metric example

Metric-sized buffer seals are designated by MPS at the start of the part number followed by rod diameter, outside groove diameter, groove height and then buffer seal type.

MPS-050-065,1-06,3-R

Inch example

Inch-sized buffer seals are designated by buffer seal style, series and then inside diameter.

R201000

Position

Buffer seals are positioned inboard from the rod seal, protecting the primary rod seal from pressure spikes that may occur in the system, preventing possible extrusion damage to the primary seal.

Product tables

See **page 28** for metric sized and **page 30** for inch sized products.

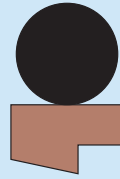

R



RS



RB

Operational range

R style buffer seal – High duty cycle

Pressure: 700 bar max (10 000 psi max)
 Temperature: -54 to +200 °C (-65 to +392 °F)
 Velocity: 1,0 m/s max (3 ft./s max)
 Surface finish: R_a 0,1 to 0,4 μm (4 to 16 μin.)

RS style buffer seal – High duty cycle

Pressure: 700 bar max (10 000 psi max)
 Temperature: -54 to +200 °C (-65 to +392 °F)
 Velocity: 1,0 m/s max (3 ft./s max)
 Surface finish: R_a 0,1 to 0,4 μm (4 to 16 μin.)

RB style buffer seal – High duty cycle

Pressure: 700 bar max (10 000 psi max)
 Temperature: -54 to +120 °C (-65 to +248 °F)
 Velocity: 1,0 m/s max (3 ft./s max)
 Surface finish: R_a 0,1 to 0,4 μm (4 to 16 μin.)

Recommended material

741 – 40% bronze filled PTFE
 A-8501 nitrile
 Customer supplied O-ring required

741 – 40% bronze filled PTFE
 A-8501 nitrile

U-1023 HP Lubrithane
 U-1027 EXHP Lubrithane
 Nylon anti-extrusion device

Gland dimensions for all inch size Buffer Seal styles for rod applications

Rod diameter d ₁	Suggested diametrical tolerances	Groove diametrical tolerances D	Groove width L	Groove depth	Cross section size Series	
in.						
0.31	1.5	+0.000 / -0.002	+0.003 / -0.000	0.126	0.149	1
0.50	2.5	+0.000 / -0.003	+0.004 / -0.000	0.166	0.212	2
1.0	8.0	+0.000 / -0.004	+0.005 / -0.000	0.247	0.308	3
4.25	12	+0.000 / -0.005	+0.006 / -0.000	0.320	0.415	4

E – Maximum diametrical clearance

Series	Material	1 000 psi	3 000 psi	5 000 psi	> 5 000 psi
for R-style					
1	741	0.018	0.016	0.008	*
2	741	0.024	0.018	0.009	*
3	741	0.030	0.024	0.018	*
4	741	0.040	0.030	0.024	*
for RB style					
3	741	0.030	0.022	0.018	*
4	741	0.040	0.028	0.016	*
for RS style					
3	741	0.030	0.024	0.018	*
4	741	0.040	0.030	0.024	*
3	707	0.040	0.030	0.024	*
4	707	0.046	0.036	0.030	*

* Consult SKF Polyseal

Buffer seals – metric sizes

d_1 10 – 350 mm

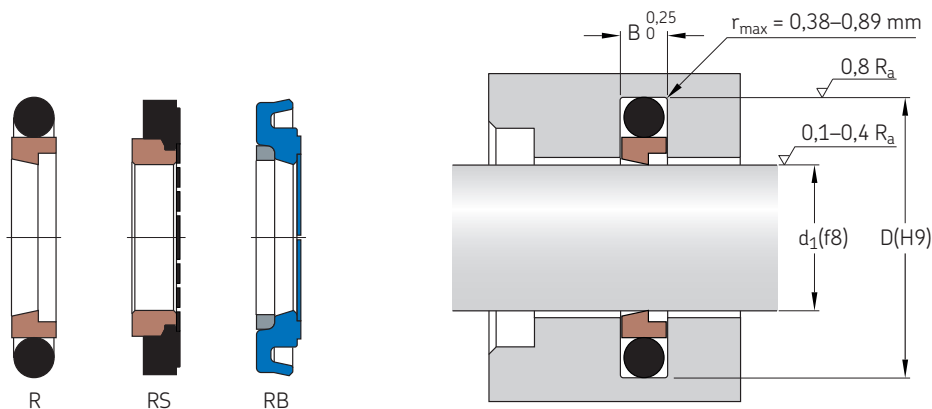

Dimensions			Designation*	Dimensions			Designation*
d_1	D	B		d_1	D	B	
mm			–	mm			–
10	17,3	3,2	MPS-010-17,3-03,2-*	105	120,1 120,5	6,3	MPS-105-120,1-06,3-* MPS-105-120,5-06,3-*
15	22,3	3,2	MPS-015-22,3-03,2-*	110	125,1 125,5	6,3	MPS-110-125,1-06,3-* MPS-110-125,5-06,3-*
18	25,3	3,2	MPS-018-25,3-03,2-*	115	130,1 130,5	6,3	MPS-115-130,1-06,3-* MPS-115-130,5-06,3-*
20	27,3 30,7	3,2 4,2	MPS-020-27,3-03,2-* MPS-020-30,7-04,2-*	120	135,1	6,3	MPS-120-135,1-06,3-*
25	35,7	4,2	MPS-025-35,7-04,2-*	125	140,1 140,5	6,3	MPS-125-140,1-06,3-* MPS-125-140,5-06,3-*
30	40,7	4,2	MPS-030-40,7-04,2-*	130	145,1 145,5	6,3	MPS-130-145,1-06,3-* MPS-130-145,5-06,3-*
36	46,7	4,2	MPS-036-46,7-04,2-*	135	150,1 150,5	6,3	MPS-135-150,1-06,3-* MPS-135-150,5-06,3-*
40	55,1	6,3	MPS-040-55,1-06,3-*	140	155,1 155,5	6,3	MPS-140-155,1-06,3-* MPS-140-155,5-06,3-*
45	60,1	6,3	MPS-045-60,1-06,3-*	150	165,1 165,5	6,3	MPS-150-165,1-06,3-* MPS-150-165,5-06,3-*
50	60,7 65,1	4,2 6,3	MPS-050-60,7-04,2-* MPS-050-65,1-06,3-*	160	175,1 175,5	6,3	MPS-160-175,1-06,3-* MPS-160-175,5-06,3-*
55	70,1	6,3	MPS-055-70,1-06,3-*	170	185,1 185,5	6,3	MPS-170-185,1-06,3-* MPS-170-185,5-06,3-*
60	75,1	6,3	MPS-060-75,1-06,3-*	180	195,1 195,5	6,3	MPS-180-195,1-06,3-* MPS-180-195,5-06,3-*
63	78,1	6,3	MPS-063-78,1-06,3-*	190	205,1 205,5	6,3	MPS-190-205,1-06,3-* MPS-190-205,5-06,3-*
65	80,1	6,3	MPS-065-80,1-06,3-*	200	220,5 221	8,1	MPS-200-220,5-08,1-* MPS-200-221-08,0-*
70	85,1 85,5	6,3 6,3	MPS-070-85,1-06,3-* MPS-070-85,5-06,3-*	210	230,5 231	8,1	MPS-210-230,5-08,1-* MPS-210-231-08,0-*
75	90,1 90,5	6,3 6,3	MPS-075-90,1-06,3-* MPS-075-90,5-06,3-*	220	240,5	8,1	MPS-220-240,5-08,1-*
80	95,1 95,5	6,3 6,3	MPS-080-95,1-06,3-* MPS-080-95,5-06,3-*	230	250,5	8,1	MPS-230-250,5-08,1-*
85	100,1 100,5	6,3 6,3	MPS-085-100,1-06,3-* MPS-085-100,5-06,3-*	240	260,5	8,1	MPS-240-260,5-08,1-*
90	105,1 105,5	6,3 6,3	MPS-090-105,1-06,3-* MPS-090-105,5-06,3-*	250	270,5	8,1	MPS-250-270,5-08,1-*
95	110,1 110,5	6,3 6,3	MPS-095-110,1-06,3-* MPS-095-110,5-06,3-*				
100	115,1 115,5	6,3 6,3	MPS-100-115,1-06,3-* MPS-100-115,5-06,3-*				

* R, RS or RB, depending on style.

Dimensions			Designation*
d ₁	D	B	
mm			–
260	284	8,1	MPS-260-284-08,1-*
270	294	8,1	MPS-270-294-08,1-*
280	304	8,1	MPS-280-304-08,1-*
290	314	8,1	MPS-290-314-08,1-*
300	324	8,1	MPS-300-324-08,1-*
310	334	8,1	MPS-310-334-08,1-*
320	344	8,1	MPS-320-344-08,1-*
330	354	8,1	MPS-330-354-08,1-*
340	364	8,1	MPS-340-364-08,1-*
350	374	8,1	MPS-350-374-08,1-*

Buffer seals – inch sizes

d_1 1.000 – 16.000 in

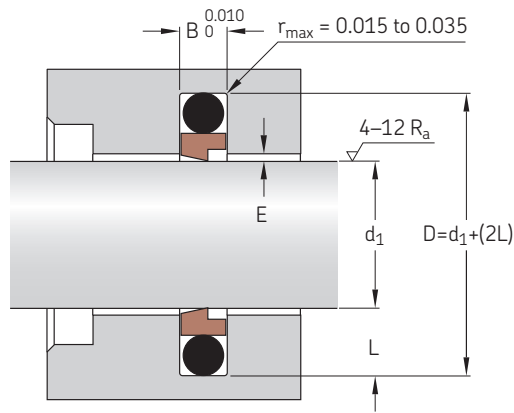
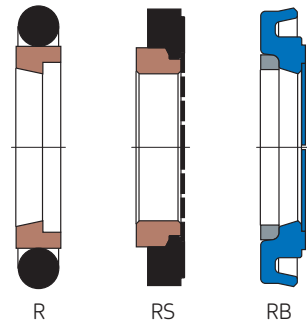

E = maximum extrusion gap.
Largest gap permitted by tolerances and eccentricity.
B = groove.
L = groove width.

See page 27.

Rod diameter	Designations			
d_1	R style	O-ring for R style	RB style	RS style
in.	–			
1.000	R101000 R201000	OR-122 OR-217		
1.250	R101250 R201250	OR-126 OR-221		
1.500	R101500 R201500 R301500	OR-130 OR-223 OR-327		
1.750	R201750 R301750	OR-225 OR-329		
2.000	R202000 R302000	OR-227 OR-331		
2.250	R202250 R302250	OR-229 OR-333		
2.500	R202500 R302500	OR-231 OR-335	RB302500	RS302500
2.750	R202750 R302750	OR-233 OR-337	RB302750	RS302750
3.000	R203000 R303000	OR-235 OR-339	RB303000	RS303000
3.250	R303250	OR-341	RB303250	RS303250
3.500	R303500	OR-343	RB303500	RS303500
3.750	R303750	OR-345	RB303750	RS303750
4.000	R304000 R404000	OR-347 OR-424	RB304000 RB404000	RS304000 RS404000
4.250	R304250 R404250	OR-349 OR-426	RB304250 RB404250	RS304250 RS404250
4.500	R304500 R404500	OR-351 OR-428	RB304500 RB404500	RS304500 RS404500
4.750	R304750 R404750	OR-353 OR-430	RB304750 RB404750	RS304750 RS404750
5.000	R305000 R405000	OR-355 OR-432	RB305000 RB405000	RS305000 RS405000
5.250	R305250 R405250	OR-357 OR-434	RB305250 RB405250	RS305250 RS405250

Rod diameter d ₁ in.	Designations			
	R style	O-ring for R style	RB style	RS style
5.500	R305500 R405500	OR-359 OR-436	RB305500 RB405500	RS305500 RS405500
5.750	R305750 R405750	OR-361 OR-437	RB305750 RB405750	RS305750 RS405750
6.000	R306000 R406000	OR-362 OR-438	RB306000 RB406000	RS306000 RS406000
6.250	R306250 R406250	OR-363 OR-439	RB306250 RB406250	RS306250 RS406250
6.500	R306500 R406500	OR-364 OR-440	RB306500 RB406500	RS306500 RS406500
6.750	R306750 R406750	OR-365 OR-441	RB306750 RB406750	RS306750 RS406750
7.000	R307000 R407000	OR-366 OR-442	RB307000 RB407000	RS307000 RS407000
7.250	R307250 R407250	OR-367 OR-443	RB307250 RB407250	RS307250 RS407250
7.500	R307500 R407500	OR-368 OR-444	RB307500 RB407500	RS307500 RS407500
7.750	R307750 R407750	OR-369 OR-445	RB307750 RB407750	RS307750 RS407750
8.000	R308000 R408000	OR-370 OR-445	RB308000 RB408000	RS308000 RS408000
8.500	R408500	OR-446		RS408500
9.000	R409000	OR-447		RS409000
9.500	R409500	OR-448		RS409500
10.000	R410000	OR-449		RS410000
10.500	R410500	OR-450		RS410500
11.000	R411000	OR-451		RS411000
11.500	R411500	OR-452		RS411500
12.000	R412000	OR-453		RS412000
12.500				RS412500
13.000				RS413000
13.500				RS413500
14.000				RS414000
14.500				RS414500
15.000				RS415000
15.500				RS415500
16.000				RS416000

Spectraseal

Spectraseals are engineered plastic seals incorporating a metallic spring, which loads the seal lips against the mating hardware, creating a seal. The spring also allows the seal to follow minor eccentricity and compensates for seal lip wear in dynamic applications.

Spectraseals are normally used in single acting applications and should be oriented with the spring cavity toward the pressure side. Pressure from the media being sealed provides an additional sealing force as it acts upon the sealing lips. The seal jacket is produced from a filled PTFE material or other plastic materials such as PEEK, UHMWPE, Acetal or Nylon.

Spectraseals are typically used in applications where conventional elastomer seals are not acceptable due to application conditions such as:

- Media compatibility
- Friction sensitive applications
- Dynamic sealing of abrasive or non-lubricating media
- Temperature extremes: -267 to $+287$ °C (-450 to $+550$ °F)
- High surface speeds
- High PV rates (Pressure x Velocity)
- Explosive decompression

Application conditions determine seal material selection and seal lip style. In static applications, a soft material such as unfilled PTFE is used for optimum sealability. In dynamic applications, harder materials that have better wear resistance are recommended. Different seal lip styles are offered to address specific applications and various media that are sealed. If you have further questions or would like to review your specific application with one of our design engineers, please contact the SKF Polyseal engineering department.

The part numbering system allows you to specify a specific seal height as long as it meets the minimum height requirements provided in column B and B₁.

Metric part number description

MSS-X-B-03,18-063,5-04,06-A-776

MSS Metric Spectraseal	X ID lip style	B OD lip style	03,18 Gland cross section L dim.	063,5 Rod or gland diameter	04,06 Seal height W dim.	A Spring material	776 Seal jacket
-------------------------------------	--------------------------------	--------------------------------	---	---	--	--------------------------------	------------------------------

Spring material

Spring type	301 Stainless	17-7 PH	Elgiloy
Cantilever	* (A)		** (B)
Helical wound		* (C)	** (D)

* While stainless steel 301 and 17-7 PH are suitable for most applications,

** Elgiloy, which is a cobalt nickel alloy, is a premium grade material. This material offers improved load deflection properties and chemical resistance. Elgiloy meets the requirements of NACE (National Association of Corrosion Engineers).

Columns B and B₁ provide typical gland heights and corresponding seal heights. The min. B and B₁ dimensions can be used when axial space is limited. This gland and seal height should not be used at higher pressures where seal extrusion would be a concern. Standard B and B₁ dimensions are similar to the gland heights required for elastomer O-rings. Heavy B and B₁ dimensions are for severe applications where high pressures and high temperatures could cause excessive extrusion of the seal (→ pages 36 to 37).

Please consult with the SKF Polyseal engineering department for design recommendations if your gland dimensions do not fit within the possible cross-section range, or your gland widths (B₁) do not meet SKF Polyseal minimum width requirements. A non-standard design could possibly be offered to fit your existing gland dimensions.

Seal lip styles

A (Cantilever spring / single radius)



Advantages

Low wear rate. Oscillatory, slow rotary applications. Radius lip reduces seal lip damage during installation

Disadvantages

Should not be used for dynamic sealing of abrasive media. May weep in high speed reciprocating applications due to seal lip hydroplaning

B (Cantilever spring / beveled lip)



Improved stability, preferred design for dynamic sealing of gas/vapors. Bevel lip reduces seal lip damage during installation

Should not be used for dynamic sealing of abrasive media. May weep in high speed reciprocating applications due to seal lip hydroplaning

D (Cantilever spring / scraper lip)



Locks seal in to reduced glands. Reduced probability of seal lip hydroplaning. Low wear rate. Good excluder for debris/contamination

Requires good lead-in chamfer if hardware is installed lip first. Possible weepage of light fluids or gases

S (Cantilever spring / double radius)



Low wear rate. Redundant seal lip design. Trapped fluid between contact points provide added lubrication to seal

Should not be used for dynamic sealing of abrasive media. May weep in high speed reciprocating applications due to seal lip hydroplaning

X (Cantilever spring / improved scraper lip)



Improved sealability over D style lip. Preferred lip design for dynamic sealing of abrasive media. Reduced probability of seal lip hydroplaning

Requires good lead-in chamfer if hardware is installed lip first. Lip design must be used in combination with other lip styles

H (Helical wound spring / radius lip)



High load of helical wound spring improves sealability. Suitable for sealing cryogenic gases and fluids. Radius lip reduces seal lip damage during installation

Should not be used for dynamic sealing of abrasive media. May weep in high speed reciprocating applications due to seal lip hydroplaning

W (Helical wound spring / scraper lip)



High load of helical wound spring improves sealability. Preferred lip design for dynamic sealing or abrasive media. Reduces probability of seal lip hydroplaning

Requires good lead-in chamfer if hardware is installed lip first. Lip design must be used in combination with radius lip style

Seal extrusion

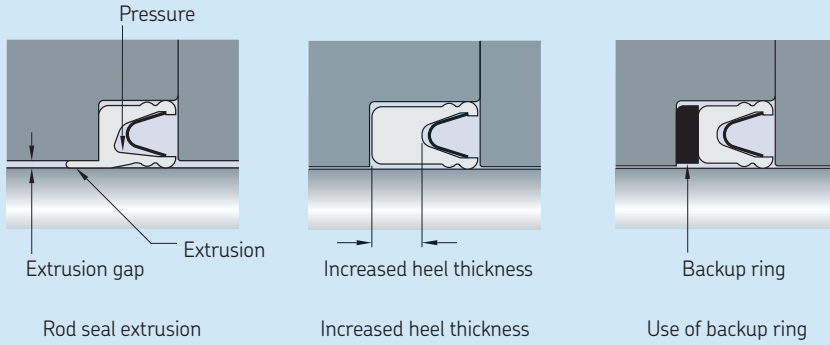

Maximum extrusion gaps at various pressures and temperatures

Seal cross section mm	Temperature max. °C	Extrusion gap max. mm					
		35 bar	69 bar	207 bar	345 bar	517 bar	689 bar
1,60	95	0,15	0,13	0,08	0,05	*	*
	150	0,13	0,10	0,05	*	*	*
	200	0,10	0,08	*	*	*	*
	260	0,08	0,05	*	*	*	*
2,39	95	0,23	0,18	0,10	0,05	0,05	*
	150	0,20	0,15	0,05	*	*	*
	200	0,18	0,10	0,05	*	*	*
	260	0,13	0,05	*	*	*	*
3,18	95	0,30	0,25	0,13	0,08	0,05	*
	150	0,28	0,20	0,08	0,05	*	*
	200	0,25	0,13	0,05	*	*	*
	260	0,15	0,08	*	*	*	*
4,78	95	0,46	0,41	0,15	0,10	0,08	0,05
	150	0,43	0,30	0,10	0,05	0,05	*
	200	0,33	0,18	0,05	*	*	*
	260	0,20	0,10	*	*	*	*
6,35	95	0,64	0,58	0,20	0,13	0,08	0,05
	150	0,58	0,36	0,13	0,08	0,05	*
	200	0,43	0,20	0,08	0,05	*	*
	260	0,25	0,13	0,05	*	*	*

* Consult SKF Polyseal engineering

Rockwell hardness

Velocity m/s	Hardness <30 RC	Hardness	
		45 RC	58 RC
0 to 0,25	A or B	A, B or C	A, B or C
0,26 to 0,50	A	A or B	A, B or C
0,51 and up	A	A or B	A or B

High pressure can cause the seal jacket material to flow into the extrusion gap in the hardware resulting in distortion of the seal causing leakage and/or premature seal failure. Higher temperatures and dynamics increase the possibility of extrusion. Increasing the heel thickness behind the spring will prevent extrusion in many cases.

For demanding applications, a backup ring produced from a stronger material such as nylon, acetal or PEEK might be used to prevent extrusion.

This table provides the maximum recommended extrusion gaps for filled PTFE Spec-traseals at various temperatures and pressures. If your application exceeds these conditions, please consult with the SKF Polyseal engineering department for design assistance.

Extrusion gaps are based on standard seal widths and the use of a filled PTFE for the seal jacket material. When using unfilled PTFE, gaps should be reduced to the next higher pressure rating.

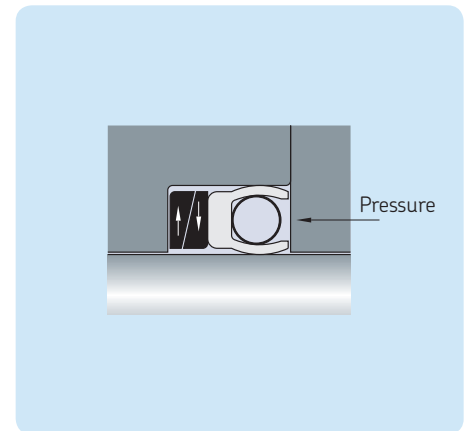

Delta backup rings

Seal design for extreme pressures utilizing delta type backup rings to bridge extrusion gap. Axial force from the seal causes the taper of the backup ring to load radially. This minimizes the extrusion gap. This type of backup ring is frequently used in high pressure piston applications where there is a potential of cylinder growth. Delta backup rings are typically manufactured from high strength plastic material such as nylon, acetal or PEEK.

Spectraseal seal jacket compounds

Spectraloy compound number	Temperature rating				*Wear resistance	*Chemical resistance	*Mating surface hardness	Compound features and recommended service
	from	to	from	to				
–	°C		°F		–	–	–	–
700	–268	+232	–450	+450	P	E	A	Unfilled PTFE: Used predominately for static or slow speed/intermittent service. Excellent for cryogenic service. FDA compliant.
716	–268	+260	–450	+500	F	E	A	15% graphite filled PTFE: Very low coefficient of friction. Used in low-pressure dynamic applications that are friction sensitive.
755	–268	+288	–450	+550	G	G	A	Ekonal filled PTFE: Good wear resistance but is not abrasive against non-hardened surfaces. Should not be used in steam applications.
756	–268	+288	–450	+550	E	G	A	Polyimide filled PTFE: Excellent wear resistance but is not abrasive against non-hardened surfaces. Should not be used in steam applications.
771	–268	+288	–450	+550	E	G	B	Mineral moly filled PTFE: Excellent wear resistance. Typically used for dynamic sealing at higher temperatures and pressures.
721	–268	+288	–450	+550	G	G	B	Mineral filled PTFE: Filler is an FDA approved mineral. Used for sealing food products at temperatures greater than 80 °C (176 °F).
734	–268	+288	–450	+550	G	E	B	10% carbon graphite filled PTFE: General-purpose material. Suitable for dynamic sealing of steam and water.
702	–268	+288	–450	+550	E	E	C	Glass, moly filled PTFE: Excellent wear and creep resistance at elevated temperatures. Good abrasion resistance for sealing non-lubricated media at high temperatures and pressures.
703	–268	+288	–450	+550	E	E	C	PPS, carbon and moly filled PTFE: Excellent wear rate in non-lubricated service at high temperatures and pressures.
782	–268	+288	–450	+550	E	E	C	Carbon fiber filled PTFE: Excellent wear and creep resistance at elevated temperatures. Good abrasion resistance for sealing non-lubricated media at elevated temperatures.
790	–268	+288	–450	+550	E	E	C	Carbon fiber filled modified PTFE: Similar to #782 but modified polymer improves wear and product surface finish. Good abrasion resistance for sealing non-lubricated media at elevated temperatures.
711	–268	+288	–450	+550	E	E	C	25% carbon graphite filled PTFE: Similar to #734 but additional filler improves wear, creep and extrusion resistance especially at elevated temperatures.
741	–268	+288	–450	+550	E	P	B	40% bronze filled PTFE: Suited for high-speed dynamic sealing of lubricating media. Should not be used for chemical service.
776	–268	+80	–450	+176	E	G	A	UHMWPE: FDA and USDA 3A approved. Best material for reciprocating service in water or water-based fluids. Typically used for sealing food products, paints, adhesives and resins. Excellent abrasion resistance.
745	–73	+288	–100	+550	G	G	B	Unfilled PEEK: High strength material predominately used for anti-extrusion devices. Suitable for sealing non-lubricating, viscous fluids from ambient to 288 °C (550 °F).

* Material comparison: E = Excellent G = Good F = Fair P = Poor

Rod style gland
L 1.6 – 9.53 in.

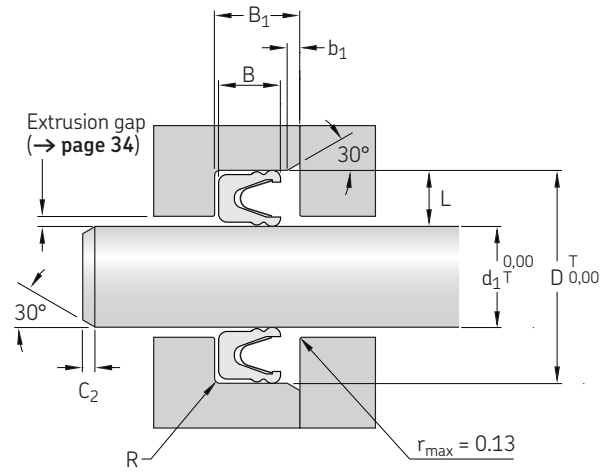
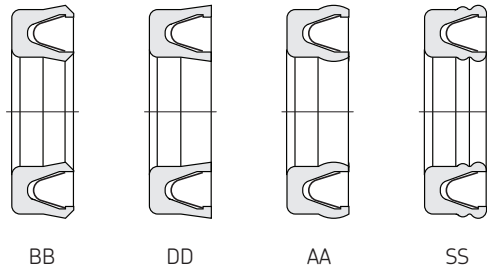

Dimensions

Standard L	L		B ₁ min.* -0/+0.25	B ₁ standard	B ₁ heavy**	B min. ±0.13	B standard	B heavy	R max.	d ₁ min.	suggested max. d ₁ ***	T	b ₁ -0/+0.13	C ₂ min.
	from	to												
in.														
1.6	1.40	2.16	-	2.39	3.79	-	2.03	3.28	0.25	3.81	89	0.05	0.20	0.51
2.39	2.18	2.79	3.18	3.56	4.65	2.74	3.07	4.06	0.30	6.35	140	0.05	0.25	0.76
3.18	2.82	3.13	3.78	4.75	5.97	3.30	4.14	5.23	0.38	7.62	200	0.05	0.38	1.02
4.78	3.76	5.77	4.88	7.14	8.48	4.27	6.30	7.52	0.51	12.07	500	0.08	0.56	1.27
6.35	5.79	7.95	7.32	9.53	12.07	6.48	8.46	10.74	0.89	25.40	1 500	0.08	0.76	2.03
9.53	7.98	11.13	9.88	12.06	15.29	8.79	10.74	13.64	1.02	31.75	1 500	0.10	1.02	2.54

Standard cross-sections are shown in column Std. L. Non-standard cross-sections should fit within the possible range shown in column L. Column T shows tolerances for standard glands and non-standard glands.

* Minimum seal jacket axial length due to depth required for spring energized cavity.
 ** Greater heel axial thickness provides improved resistance to seal deformation into the extrusion gap.
 *** For greater diameter considerations, please contact SKF Polyseal Engineering.

Piston style gland
L 1.6 – 6.35 in.

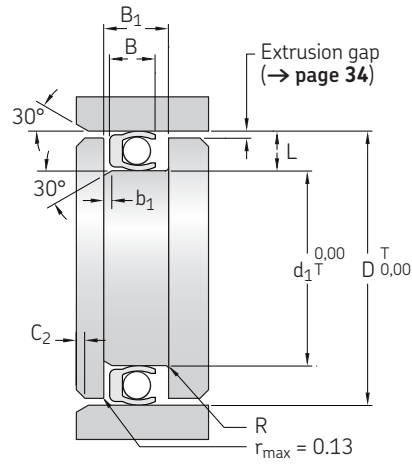
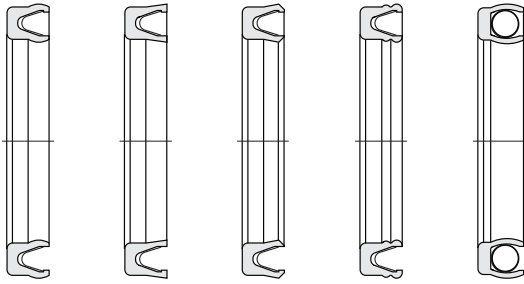

Dimensions

Standard L	L from	to	B ₁ min. -0/+0.25	B ₁ standard	B ₁ heavy	B min. ±0.13	B standard	B heavy	R max.	d ₁ min.	suggested max d ₁ *	T	b ₁ -0/+0.13	C ₂ min.
---------------	-----------	----	------------------------------------	----------------------------	-------------------------	--------------------	---------------	------------	-----------	------------------------	-----------------------------------	---	----------------------------	------------------------

in.

1.6	1.52	2.03	2.24	2.39	3.79	1.91	2.03	3.28	0.25	2.36	89	0.05	0.20	0.51
2.39	2.26	2.64	3.10	3.56	4.64	2.6	3.07	4.06	0.30	3.18	140	0.05	0.25	0.76
3.18	3.07	3.45	4.09	4.75	5.97	3.56	4.14	5.23	0.38	6.35	200	0.05	0.38	1.02
4.78	4.72	5.16	6.05	7.14	8.49	5.33	6.30	7.52	0.51	12.70	500	0.08	0.56	1.27
6.35	6.05	6.88	7.80	9.53	12.07	6.91	8.46	10.74	0.89	22.23	1 500	0.08	0.76	2.03

* For greater diameter considerations, please contact SKF Polyseal Engineering.

Rod wipers

Press-fit wipers

Metal clad wipers (MC)

The wiper is rigid enough to handle the toughest of scraping environments such as dry/wet mud and ice, yet sensitive enough to exclude fine dust and moisture. The MC series contains a Lubrithane element encased in a metal retainer, providing both a mechanical bond because the Lubrithane overlaps a portion of the retainer as well as a good chemical bond. A high quality steel metal retaining ring of the proper wall thickness provides adequate strength for the various diameters.

Self cleaning wiper (SC)

Specifically designed lip keeps mud, cement and other similar substances from hardening in the wiper. The RL style wiper lip provides a reduction in apparent and rod seal leakage while maintaining equivalent ingress resistance to a sharp lip wiper.

SH wiper

A one piece press-in type rod wiper designed with a secondary U-Cup. The RL style wiper lip provides a reduction in apparent and rod seal leakage while maintaining equivalent ingress resistance to a sharp lip wiper.

Part number description

Metric example

Metric-sized press-fit wipers are designated by MPS at the start of the part number followed by inside rod diameter, outside groove diameter, groove height then press-fit wiper style.

MPS-020-032-06,0-MC

Inch example

Inch-sized press-fit wipers are designated by press-fit wiper style and then rod diameter.

MC-0500



	Operational range	Recommended materials
MC, SC and SH wiper		
Temperature:	-40 to +120 °C (-40 to +248 °F)	U-1023 HP Lubrithane (→ page 8)
Velocity:	1,0 m/s max (3 ft./s max)	U-1003 Lubrithane 100 °C (212 °F)
Surface finish:	R _a 0,1 to 0,4 μm (4 to 16 μin.)	U-1029 Lubrithane (→ page 8)

Product tables

See **page 39** for metric sized and **page 40** for inch sized products.

Press-fit wipers – metric sizes

d_1 20 – 160 mm

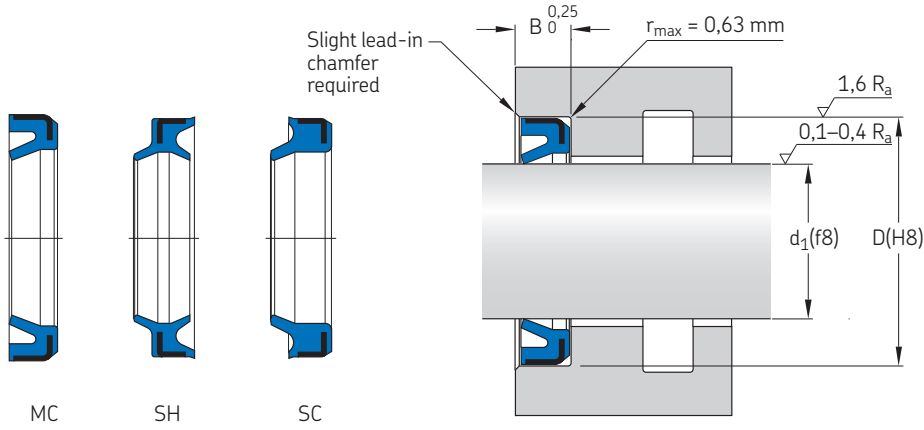

Dimensions

Designation*

d_1 D B

mm

d_1	D	B	Designation*
20	32	6	MPS-020-032-06-*
30	42	6	MPS-030-042-06-*
35	47	7	MPS-035-047-07-*
40	52	7	MPS-040-052-07-*
45	57	7	MPS-045-057-07-*
50	62	7	MPS-050-062-07-*
55	69	8	MPS-055-069-08-*
60	74	8	MPS-060-074-08-*
65	79	8	MPS-065-079-08-*
70	84	8	MPS-070-084-08-*
75	89	8	MPS-075-089-08-*
80	94	8	MPS-080-094-08-*
85	99	8	MPS-085-099-08-*
90	104	8	MPS-090-104-08-*
95	109	8	MPS-095-109-08-*
100	114	8	MPS-100-114-08-*
105	121	9	MPS-105-121-09-*
110	126	9	MPS-110-126-09-*
120	136	9	MPS-120-136-09-*
130	146	9	MPS-130-146-09-*
140	160	10	MPS-140-160-10-*
150	170	10	MPS-150-170-10-*
160	180	10	MPS-160-180-10-*

* MC, SH or SC, depending on style.

Press-fit wipers – inch sizes

d_1 0.500 – 6.750 in

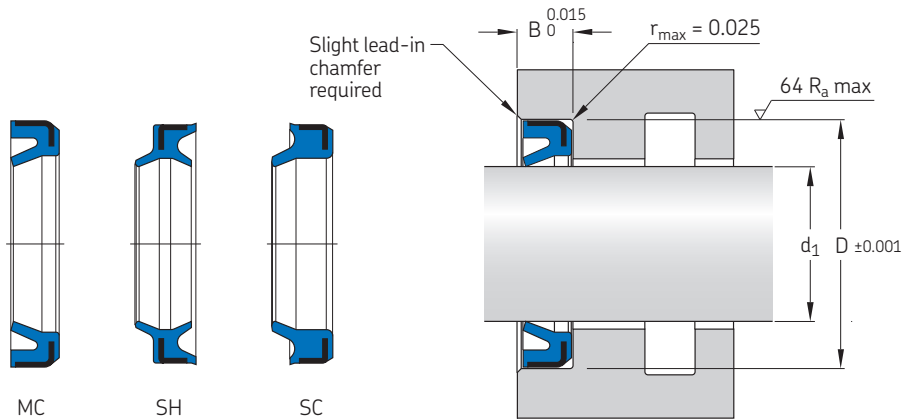

Dimensions			Designation*	Dimensions			Designation*
d_1	D	B		d_1	D	B	
in.			–	in.			–
0.500	1.000	0.250	*-0500	3.375	4.000	0.312	*-3375
0.625	1.125	0.312	*-0625	3.500	4.125	0.312	*-3500
0.750	1.250	0.312	*-0750	3.625	4.250	0.312	*-3625
0.875	1.375	0.312	*-0875	3.750	4.375	0.312	*-3750
1.000	1.500	0.312	*-1000	3.875	4.500	0.312	*-3875
1.125	1.625	0.312	*-1125	4.000	4.625	0.312	*-4000
1.250	1.750	0.312	*-1250	4.125	4.750	0.312	*-4125
1.375	1.875	0.312	*-1375	4.250	4.875	0.312	*-4250
1.500	2.000	0.312	*-1500	4.375	5.000	0.312	*-4375
1.625	2.125	0.312	*-1625	4.500	5.125	0.312	*-4500
1.750	2.250	0.312	*-1750	4.750	5.375	0.312	*-4750
1.875	2.375	0.312	*-1875	5.000	5.625	0.312	*-5000
2.000	2.500	0.312	*-2000	5.250	5.875	0.312	*-5250
2.125	2.625	0.312	*-2125	5.500	6.125	0.375	*-5500
2.250	2.750	0.312	*-2250	5.750	6.375	0.375	*-5750
2.375	2.875	0.312	*-2375	6.000	6.625	0.375	*-6000
2.500	3.000	0.312	*-2500	6.750	7.375	0.375	*-6750
2.625	3.125	0.312	*-2625				
2.750	3.250	0.312	*-2750				
2.875	3.375	0.312	*-2875				
3.000	3.500	0.312	*-3000				
3.125	3.750	0.312	*-3125				
3.250	3.875	0.312	*-3250				

* MC, SH or SC, depending on style.

Snap-in wipers

DT (slotted) wiper

This wiper is ideal for most applications including contaminated environments.

DX Wiper

Used in applications with severe side deflections. Radius wiper lip reduces apparent rod seal leakage with equivalent ingression resistance to a sharp lip wiper. O-ring must be installed for proper performance.

H Wiper

These are one-piece snap-in type rod wipers designed for light duty applications. The U-Cup portion of these wipers serves as a secondary safeguard against leakage past the primary rod seal. H Wipers are not pressure seals.

DS wiper

The DS wiper has a slotted heel, which helps vent backpressure. Raised portions on the outside diameter provide improved outside diameter ingression resistance.



DT

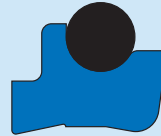

DX

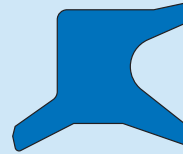

H

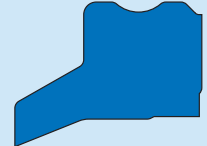

DS

	Operational range	Recommended material
DT wiper – High duty cycle U-1003 Lubrithane 100 °C (212 °F)	Temperature: –40 to +120 °C (–40 to +248 °F)	U-1023 HP Lubrithane
Velocity: 1,0 m/s max (3 ft./s max)		
Rod surface finish: R_a 0,1 to 0,4 μm (4 to 16 $\mu\text{in.}$)		
DX wiper – High duty cycle U-1003 Lubrithane 100 °C (212 °F)	Temperature: –40 to +120 °C (–40 to +248 °F)	U-1003 Lubrithane U-1004 Lubrithane
Velocity: 1,0 m/s max (3 ft./s max)		
Rod surface finish: R_a 0,1 to 0,4 μm (4 to 16 $\mu\text{in.}$)		
H wiper – Medium duty cycle U-1003 Lubrithane 100 °C (212 °F)	Temperature: –40 to +100 °C (–40 to +212 °F)	U-1003 Lubrithane
Velocity: 1,0 m/s max (3 ft./s max)		
Rod surface finish: R_a 0,1 to 0,4 μm (4 to 16 $\mu\text{in.}$)		
DS wiper – High duty cycle U-1003 Lubrithane 100 °C (212 °F)	Temperature: –40 to +100 °C (–40 to +212 °F)	U-1003 Lubrithane
Velocity: 1,0 m/s max (3 ft./s max)		
Rod surface finish: R_a 0,1 to 0,4 μm (4 to 16 $\mu\text{in.}$)		

Part number description

Metric example

Metric-sized snap-in wipers are designated by MPS at the start of the part number followed by inside rod diameter, outside groove diameter, groove height and then snap-in wiper style.

MPS-016-024-04,5-DT

Inch example

Inch-sized snap-in wipers are designated by snap-in wiper style and then rod diameter.

DT-0500

Product tables

See **page 42** for metric sized and **page 43** for inch sized products.

Snap-in wipers – metric sizes

d_1 16 – 145 mm

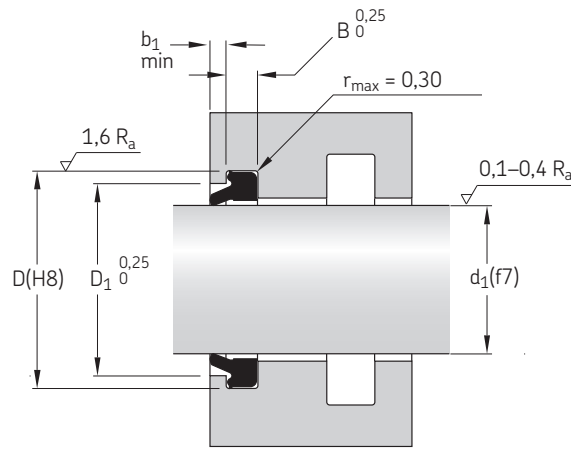
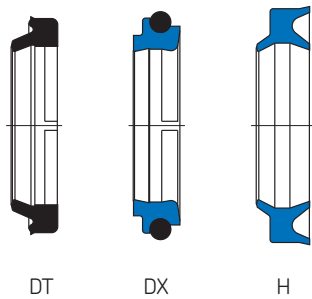

Dimensions					Designation*	Dimensions					Designation*
Rod diameter d_1	Groove diameter D	Groove width B	Shoulder diameter D_1 +0,25/-0	b_1 +0,10/-0		Rod diameter d_1	Groove diameter D	Groove width B	Shoulder diameter D_1 +0,25/-0	b_1 +0,10/-0	
mm					-	mm					-
16	24	5	20,3	2	MPS-016-024-04,5-*	80	90	7	85	3	MPS-080-090-06,0-*
18	26	5	22,3	2	MPS-018-026-04,5-*	85	95	7	90	3	MPS-085-095-06,0-*
20	28	5	24,3	2	MPS-020-028-04,5-*	90	100	7	95	3	MPS-090-100-06,0-*
22	30	5	26,3	2	MPS-022-030-04,5-*	95	105	7	100	3	MPS-095-105-06,0-*
22,4	30,4	5	26,7	2	MPS-22,4-30,4-04,5-*	100	110	7	105	3	MPS-100-110-06,0-*
25	33	5	29,3	2	MPS-025-033-04,5-*	112	122	7	117	3	MPS-112-122-06,0-*
28	36	5	32,3	2	MPS-028-036-04,5-*	125	138	8	132	3	MPS-140-153-07,0-*
30	38	6	34	2	MPS-030-038-05,0-*	140	153	8	147	3	MPS-140-153-07,0-*
31,5	39,5	6	35,5	2	MPS-31,5-39,5-05,0-*	145	158	8	152	3	MPS-145-158-07,0-*
32	40	6	36	2	MPS-032-040-05,0-*						
35	43	6	39	2	MPS-035-043-05,0-*						
35,5	43,5	6	39,5	2	MPS-35,5-43,5-05,0-*						
36	44	6	40	2	MPS-036-044-05,0-*						
40	48	6	44	2	MPS-040-048-05,0-*						
45	53	6	49	2	MPS-045-053-05,0-*						
50	58	6	54	2	MPS-050-058-05,0-*						
55	63	6	59	2	MPS-055-063-05,0-*						
56	64	6	60	2	MPS-056-064-05,0-*						
60	68	6	64	2	MPS-060-068-05,0-*						
63	71	6	67	2	MPS-063-071-05,0-*						
65	73	6	69	2	MPS-065-073-05,0-*						
70	80	7	75	3	MPS-070-080-06,0-*						
71	81	7	76	3	MPS-071-081-06,0-*						
75	85	7	80	3	MPS-075-085-06,0-*						

* DT, DX or H, depending on style.

Snap-in wipers – inch sizes

d₁ 0.250 – 13.000 in

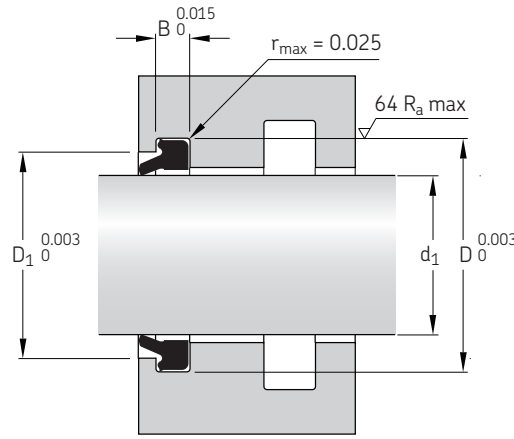
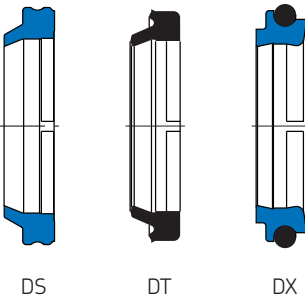

Dimensions				Designation*	Dimensions				Designation*
Rod diameter d ₁	Groove diameter D	Groove width B	Shoulder diameter D ₁		Rod diameter d ₁	Groove diameter D	Groove width B	Shoulder diameter D ₁	
in.				-	in.				-
0.250	0.497	0.124	0.410	*-0250	3.500	3.997	0.249	3.827	*-3500
0.313	0.560	0.124	0.475	*-0312	3.625	4.122	0.249	3.952	*-3625
0.375	0.622	0.124	0.535	*-0375	3.750	4.247	0.249	4.077	*-3750
0.438	0.685	0.124	0.600	*-0437	3.875	4.372	0.249	4.202	*-3875
0.500	0.747	0.124	0.660	*-0500	4.000	4.497	0.249	4.327	*-4000
0.563	0.810	0.124	0.725	*-0562	4.125	4.622	0.249	4.452	*-4125
0.625	0.872	0.124	0.785	*-0625	4.250	4.747	0.249	4.577	*-4250
0.688	0.935	0.124	0.850	*-0687	4.375	4.872	0.249	4.702	*-4375
0.750	1.122	0.187	0.995	*-0750	4.500	5.247	0.374	4.993	*-4500
0.813	1.185	0.187	1.060	*-0812	4.625	5.372	0.374	5.118	*-4625
0.875	1.247	0.187	1.120	*-0875	4.750	5.497	0.374	5.243	*-4750
0.938	1.310	0.187	1.185	*-0937	4.875	5.622	0.374	5.368	*-4875
1.000	1.372	0.187	1.245	*-1000	5.000	5.747	0.374	5.493	*-5000
1.063	1.435	0.187	1.310	*-1062	5.125	5.872	0.374	5.618	*-5125
1.125	1.497	0.187	1.370	*-1125	5.250	5.997	0.374	5.743	*-5250
1.188	1.560	0.187	1.435	*-1187	5.375	6.122	0.374	5.868	*-5375
1.250	1.622	0.187	1.495	*-1250	5.500	6.247	0.374	5.993	*-5500
1.313	1.685	0.187	1.560	*-1312	5.625	6.372	0.374	6.118	*-5625
1.375	1.747	0.187	1.620	*-1375	5.750	6.497	0.374	6.243	*-5750
1.438	1.810	0.187	1.685	*-1437	5.875	6.622	0.374	6.368	*-5875
1.500	1.875	0.187	1.745	*-1500	6.000	6.747	0.374	6.493	*-6000
1.563	1.935	0.187	1.810	*-1562	6.250	6.997	0.374	6.743	*-6250
1.625	1.997	0.187	1.870	*-1625	6.500	7.247	0.374	6.993	*-6500
1.688	2.060	0.187	1.935	*-1687	6.750	7.497	0.374	7.243	*-6750
1.750	2.122	0.187	1.995	*-1750	7.000	7.747	0.374	7.493	*-7000
1.813	2.185	0.187	2.060	*-1812	7.250	7.997	0.374	7.743	*-7250
1.875	2.247	0.187	2.120	*-1875	7.500	8.247	0.374	7.993	*-7500
1.938	2.310	0.187	2.185	*-1937	7.750	8.497	0.374	8.243	*-7750
2.000	2.497	0.249	2.327	*-2000	8.000	8.747	0.374	8.493	*-8000
2.063	2.560	0.249	2.390	*-2062	8.125	8.997	0.374	8.743	*-8250
2.125	2.622	0.249	2.452	*-2125	8.500	9.247	0.374	8.993	*-8500
2.188	2.685	0.249	2.515	*-2187	8.750	9.497	0.374	9.243	*-8750
2.250	2.747	0.249	2.577	*-2250	9.000	9.747	0.374	9.493	*-9000
2.313	2.810	0.249	2.640	*-2312	9.125	9.997	0.374	9.743	*-9250
2.375	2.872	0.249	2.702	*-2375	9.500	10.247	0.374	9.993	*-9500
2.438	2.935	0.249	2.765	*-2437	9.750	10.497	0.374	10.243	*-9750
2.500	2.997	0.249	2.827	*-2500	10.000	10.997	0.499	10.659	*-10000
2.563	3.060	0.249	2.890	*-2562	10.250	11.247	0.499	10.909	*-10250
2.625	3.122	0.249	2.952	*-2625	10.500	11.497	0.499	11.159	*-10500
2.688	3.185	0.249	3.015	*-2687	10.750	11.747	0.499	11.409	*-10750
2.750	3.247	0.249	3.077	*-2750	11.000	11.997	0.499	11.659	*-11000
2.823	3.310	0.249	3.140	*-2812	11.250	12.247	0.499	11.909	*-11250
2.875	3.372	0.249	3.202	*-2875	11.500	12.497	0.499	12.159	*-11500
2.938	3.435	0.249	3.265	*-2937	11.750	12.747	0.499	12.409	*-11750
3.000	3.497	0.249	3.327	*-3000	12.000	12.997	0.499	12.659	*-12000
3.125	3.622	0.249	3.452	*-3125	12.500	13.497	0.499	13.159	*-12500
3.250	3.747	0.249	3.577	*-3250	13.000	13.997	0.499	13.659	*-13000
3.375	3.872	0.249	3.702	*-3375					

* DS, DT or DX, depending on style.

Snap-in wipers – inch sizes

d_1 0.250 – 10.000 in

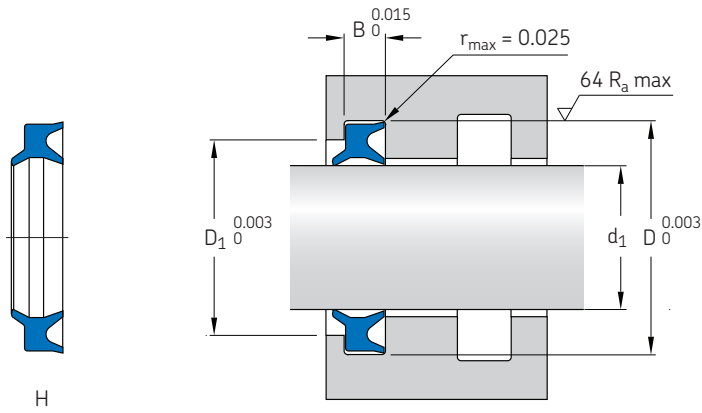

Dimensions				Designation	Dimensions				Designation
Rod diameter d_1	Groove diameter D	Groove width B	Shoulder diameter D_1		Rod diameter d_1	Groove diameter D	Groove width B	Shoulder diameter D_1	
in.				-	in.				-
0.250	0.552	0.203	0.370	H-0250	3.000	3.495	0.281	3.135	H-3000
0.312	0.615	0.203	0.432	H-0312	3.125	3.620	0.281	3.260	H-3125
0.375	0.677	0.203	0.495	H-0375	3.250	3.745	0.281	3.385	H-3250
0.437	0.740	0.203	0.557	H-0437	3.375	3.870	0.281	3.510	H-3375
0.500	0.802	0.203	0.620	H-0500	3.500	3.995	0.281	3.635	H-3500
0.562	0.865	0.203	0.682	H-0562	3.625	4.120	0.281	3.760	H-3625
0.625	0.927	0.203	0.745	H-0625	3.750	4.245	0.281	3.885	H-3750
0.688	0.990	0.203	0.808	H-0687	3.875	4.370	0.281	4.010	H-3875
0.750	1.052	0.203	0.870	H-0750	4.000	4.495	0.281	4.135	H-4000
0.812	1.177	0.218	0.947	H-0812	4.125	4.620	0.281	4.260	H-4125
0.875	1.240	0.218	1.010	H-0875	4.250	4.745	0.281	4.385	H-4250
0.937	1.302	0.218	1.072	H-0937	4.375	4.870	0.281	4.510	H-4375
1.000	1.365	0.218	1.135	H-1000	4.500	4.995	0.281	4.635	H-4500
1.062	1.427	0.218	1.197	H-1062	4.625	5.120	0.281	4.760	H-4625
1.125	1.490	0.218	1.260	H-1125	4.750	5.245	0.281	4.885	H-4750
1.187	1.552	0.218	1.322	H-1187	4.875	5.370	0.281	5.010	H-4875
1.250	1.615	0.218	1.385	H-1250	5.000	5.495	0.281	5.135	H-5000
1.312	1.702	0.218	1.447	H-1312	5.125	5.620	0.281	5.260	H-5125
1.375	1.740	0.218	1.510	H-1375	5.250	5.745	0.281	5.385	H-5250
1.437	1.802	0.218	1.572	H-1437	5.375	5.870	0.281	5.510	H-5375
1.500	1.865	0.218	1.635	H-1500	5.500	5.995	0.281	5.635	H-5500
1.562	1.927	0.218	1.697	H-1562	5.625	6.120	0.281	5.760	H-5625
1.625	1.990	0.218	1.760	H-1625	5.750	6.245	0.281	5.885	H-5750
1.688	2.052	0.218	1.823	H-1687	5.875	6.370	0.281	6.010	H-5875
1.750	2.115	0.218	1.885	H-1750	6.000	6.495	0.281	6.135	H-6000
1.812	2.177	0.218	1.947	H-1812	6.250	6.745	0.281	6.385	H-6250
1.875	2.240	0.218	2.010	H-1875	6.500	6.995	0.281	6.635	H-6500
1.937	2.302	0.218	2.072	H-1937	6.750	7.245	0.281	6.885	H-6750
2.000	2.365	0.218	2.135	H-2000	7.000	7.495	0.281	7.135	H-7000
2.062	2.427	0.218	2.197	H-2062	7.250	7.745	0.281	7.385	H-7250
2.125	2.490	0.218	2.260	H-2125	7.500	7.995	0.281	7.635	H-7500
2.188	2.683	0.281	2.323	H-2187	7.750	8.245	0.281	7.885	H-7750
2.250	2.745	0.281	2.385	H-2250	8.000	8.495	0.281	8.135	H-8000
2.312	2.807	0.281	2.447	H-2312	8.250	8.745	0.281	8.385	H-8250
2.375	2.870	0.281	2.510	H-2375	8.500	8.995	0.281	8.635	H-8500
2.437	2.932	0.281	2.572	H-2437	8.750	9.245	0.281	8.885	H-8750
2.500	2.995	0.281	2.635	H-2500	9.000	9.495	0.281	9.135	H-9000
2.562	3.057	0.281	2.697	H-2562	9.250	9.745	0.281	9.385	H-9250
2.625	3.120	0.281	2.760	H-2625	9.500	9.995	0.281	9.635	H-9500
2.688	3.183	0.281	2.832	H-2687	9.750	10.245	0.281	9.885	H-9750
2.750	3.245	0.281	2.885	H-2750	10.000	10.495	0.281	10.135	H-10000
2.812	3.307	0.281	2.947	H-2812					
2.875	3.370	0.281	3.010	H-2875					
2.938	3.433	0.281	3.073	H-2937					

Piston seals

O-ring energized piston rings

Part number descriptions

Metric example

Metric-sized O-ring energized piston rings are designated by MPS at the start of the part number followed by the series cross section, bore diameter, energizer designation (O-ring or square ring) and then material.

MPS-A-020,O-PRO-702

Inch example

Inch-sized O-ring energized piston rings are designated by type and cross section, seal diameter, cut style, other feature (if available) and then material.

P1B-04500-L-S-702

Product tables

See **page 47** for metric sized and **page 48** for inch sized products.



Chamfered rectangular



Square



Rectangular

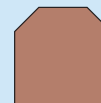

Chamfered square

Operational range

PTFE piston seal – High duty cycle

Pressure: 350 bar max. (5 000 psi max.)

Temperature: -40 to +200 °C (-40 to +400 °F)

Velocity: 1,0 m/s max (3 ft./s max)

Surface finish: R_a 0,1 to 0,4 μm (4 to 16 $\mu\text{in.}$)

Recommended material

702 – 15% glass filled, 5% molybden PTFE

711 – 25% carbon graphite filled PTFE

714 – 55% bronze, 5% molybden PTFE

741 – 40% bronze filled PTFE

Customer-supplied O-ring required

Note: Temperature is subject to customer supplied O-ring.

Maximum extrusion gaps

Series	0–100 bar (1 450 psi)	200 bar (2 900 psi)	400 bar (5 800 psi)
--------	--------------------------	------------------------	------------------------

–	mm (inch)	mm (inch)	mm (inch)
---	-----------	-----------	-----------

A	0,75 (0.030)	0,40 (0.016)	0,25 (0.010)
B	0,80 (0.031)	0,50 (0.020)	0,23 (0.009)
C	0,90 (0.035)	0,70 (0.026)	0,40 (0.016)
D	1,00 (0.039)	0,70 (0.026)	0,50 (0.020)

O-ring energized piston rings – metric sizes

d_1 12,5 – 329 mm

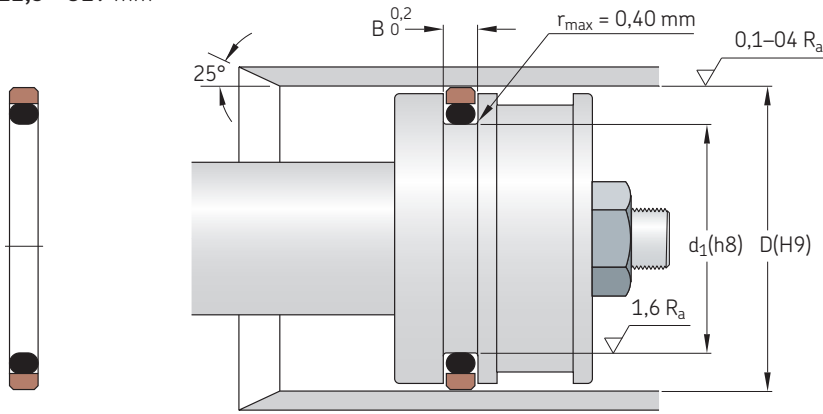

Dimensions					Series	O-ring size	Designation	Dimensions				
d_1	D	B						d_1	D	B		
mm			-	-	-	mm			-	-	-	
12,5	20	3,2	A	112	MPS-1-020,0-PRO	119	140	8,1	B	426	MPS-3-140,0-PRO	
14,5	22	3,2	A	113	MPS-1-022,0-PRO	124	145	8,1	C	428	MPS-4-145,0-PRO	
17,5	25	3,2	A	115	MPS-1-025,0-PRO	129	150	8,1	B	429	MPS-3-150,0-PRO	
20,5	28	3,2	A	117	MPS-1-028,0-PRO	134	155	8,1	C	431	MPS-4-155,0-PRO	
22,5	30	3,2	A	118	MPS-1-030,0-PRO	139	160	8,1	B	432	MPS-3-160,0-PRO	
27,5	35	3,2	A	121	MPS-1-035,0-PRO	144	165	8,1	C	434	MPS-4-165,0-PRO	
29	40	4,2	B	216	MPS-2-040,0-PRO	149	170	8,1	B	435	MPS-3-170,0-PRO	
31	42	4,2	B	217	MPS-2-042,0-PRO	154	175	8,1	C	437	MPS-4-175,0-PRO	
34	45	4,2	B	219	MPS-2-045,0-PRO	159	180	8,1	B	438	MPS-3-180,0-PRO	
39	50	4,2	B	222	MPS-2-050,0-PRO	169	190	8,1	C	439	MPS-4-190,0-PRO	
44	55	4,2	B	224	MPS-2-055,0-PRO	179	200	8,1	B	441	MPS-3-200,0-PRO	
49	60	4,2	B	225	MPS-2-060,0-PRO	189	210	8,1	C	442	MPS-4-210,0-PRO	
52	63	4,2	B	226	MPS-2-063,0-PRO	199	220	8,1	B	444	MPS-3-220,0-PRO	
54	65	4,2	B	227	MPS-2-065,0-PRO	209	230	8,1	C	445	MPS-4-230,0-PRO	
54,5	70	6,3	B	330	MPS-2-070,0-PRO	219	240	8,1	B	446	MPS-3-240,0-PRO	
59	70	4,2	B	228	MPS-2-070,0-PRO	229	250	8,1	C	447	MPS-4-250,0-PRO	
64	75	4,2	B	230	MPS-2-075,0-PRO	239	260	8,1	B	447	MPS-3-260,0-PRO	
						249	270	8,1	C	448	MPS-4-270,0-PRO	
64	85	8,1	C	409	MPS-4-085,0-PRO							
64,5	80	6,3	B	333	MPS-3-080,0-PRO	259	280	8,1	B	449	MPS-3-280,0-PRO	
69,5	85	6,3	B	335	MPS-3-085,0-PRO	269	290	8,1	C	450	MPS-4-290,0-PRO	
						279	300	8,1	B	451	MPS-3-300,0-PRO	
74	95	8,1	C	412	MPS-4-095,0-PRO							
74,5	90	6,3	B	336	MPS-3-090,0-PRO	289	310	8,1	C	451	MPS-4-310,0-PRO	
79	100	8,1	C	414	MPS-4-100,0-PRO	299	320	8,1	B	452	MPS-3-320,0-PRO	
						309	330	8,1	C	453	MPS-4-330,0-PRO	
84	105	8,1	C	415	MPS-4-105,0-PRO							
84,5	100	6,3	B	339	MPS-3-100,0-PRO	319	340	8,1	B	454	MPS-3-340,0-PRO	
89	110	8,1	C	417	MPS-4-110,0-PRO	329	350	8,1	C	454	MPS-4-350,0-PRO	
89,5	105	6,3	B	341	MPS-3-105,0-PRO							
94	115	8,1	C	418	MPS-4-115,0-PRO							
94,5	110	6,3	B	342	MPS-3-110,0-PRO							
99	120	8,1	C	420	MPS-4-120,0-PRO							
99,5	115	6,3	B	344	MPS-3-115,0-PRO							
104	125	8,1	C	421	MPS-4-125,0-PRO							
104,5	120	6,3	B	346	MPS-3-120,0-PRO							
109	130	8,1	C	423	MPS-4-130,0-PRO							
109,5	125	6,3	B	347	MPS-3-125,0-PRO							
114	135	8,1	C	425	MPS-4-135,0-PRO							
114,5	130	6,3	B	349	MPS-3-130,0-PRO							
116,5	132	6,3	B	349	MPS-3-132,0-PRO							

O-ring energized piston rings – inch sizes

d_1 0.500 – 16.000 in

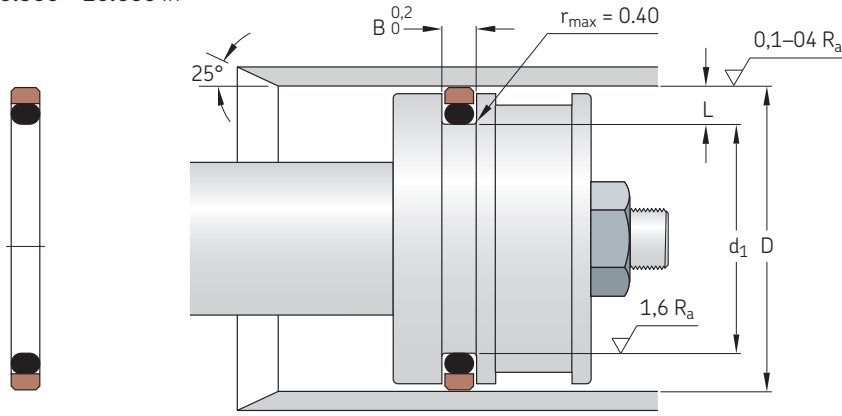

Dimensions Bore diameter D from to		Groove depth L	Groove diametrical tolerance	Groove width B	Piston ring series	O-ring square-ring series
in.		in.	in.	in.	–	–
0.500	1.500	0.087	±0.001	0.083	P0A	000
0.688	3.000	0.149	±0.001	0.128	P1A	100
1.560	5.500	0.212	±0.002	0.168	P2A	200
3.120	12.000	0.308	±0.003	0.249	P3A	300
5.250	16.000	0.415	±0.004	0.322	P4A	400
0.500	1.500	0.130	±0.002	0.083	P0B	000
1.560	1.930	0.196	±0.002	0.122	P1B	100
2.000	5.500	0.196	±0.003	0.129	P1B	100
5.600	12.000	0.259	±0.004	0.159	P2B	200
1.000	2.750	0.155	±0.001	0.129	P1C	100
3.000	5.000	0.280	±0.002	0.284	P3C	300
5.250	8.500	0.381	±0.003	0.379	P4C	400
9.000	14.000	0.439	±0.003	0.379	P4C	400
5.000	1.500	0.130	±0.002	0.083	P0D	000
1.560	1.930	0.196	±0.002	0.122	P1D	100
2.000	5.500	0.196	±0.003	0.129	P1D	100
5.600	12.000	0.259	±0.004	0.159	P2D	200
0.500	0.870	0.091	±0.001	0.113	P0E	000
0.937	2.870	0.148	±0.001	0.163	P1E	100
3.000	5.120	0.256	±0.003	0.303	P3E	300
5.250	8.500	0.360	±0.003	0.413	P4E	400
8.500	16.000	0.435	±0.004	0.413	P4E	400

Square-ring energized piston rings

Part number descriptions

Metric example

Metric-sized square-ring energized piston rings are designated by MPS at the start of the part number followed by the series cross section, bore diameter, energizer designation (O-ring or square ring) and then material.

MPS-A-020,0-PRO-702

Inch example

Inch-sized square-ring energized piston rings are designated by type and cross section, seal diameter, cut style, other feature (if available) and then material.

P1B-04500-L-S-702

Product tables

See **page 48** for metric sized.

Please consult SKF Polyseal sales or engineering for available inch sizes.



Chamfered rectangular



Square



Rectangular

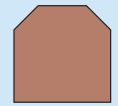

Chamfered square

Operational range

PTFE piston seal – High duty cycle
 Pressure: 350 bar (5 000 psi)
 Temperature: -40 to +200 °C (-40 to +400 °F)
 Velocity: 1,0 m/s max (3 ft./s max)
 Surface finish: R_a 0,1 to 0,4 μ m (4 to 16 μ in.)

Recommended material

702 – 15% glass filled, 5% moly PTFE
 711 – 25% carbon graphite filled PTFE
 714 – 55% bronze, 5% moly PTFE
 741 – 40% bronze filled PTFE
 Customer supplied O-ring required

Note: Temperature is subject to customer supplied O-ring.

Maximum extrusion gaps

Series	0–100 bar (1 450 psi)	200 bar (2 900 psi)	400 bar (5 800 psi)
–	mm (in.)	mm (in.)	mm (in.)
A	0,75 (0.030)	0,40 (0.016)	0,25 (0.010)
B	0,80 (0.031)	0,50 (0.020)	0,23 (0.009)
C	0,90 (0.035)	0,70 (0.026)	0,40 (0.016)
D	1,00 (0.039)	0,70 (0.026)	0,50 (0.020)

Part numbering guide

P 1B 04500 L S 702

Type and nominal cross section (see below)	Seal diameter 5 digits for bore diameter, in inches (example is a 4.500 bore)	Cut style L – Solid A – Angle B – Butt-cut S – Step-cut	Other features S – Standard N – Notched	Material See material table
--	--	---	---	--------------------------------

Type and nominal cross section

Chamfered rectangular	Square	Rectangular	Chamfered square	Rectangular (Square ring loader)
-----------------------	--------	-------------	------------------	----------------------------------

– in.

0A – 0.062	0B – 0.062	1C – 0.094	0D – 0.062	0E – 0.062
1A – 0.094	1B – 0.094	2C – 0.125	1D – 0.094	1E – 0.094
2A – 0.125	2B – 0.125	3C – 0.187	2D – 0.125	3E – 0.187
3A – 0.187		4C – 0.250		4E – 0.250
4A – 0.250				

Square-ring energized piston rings – metric sizes

D 50 – 240 mm

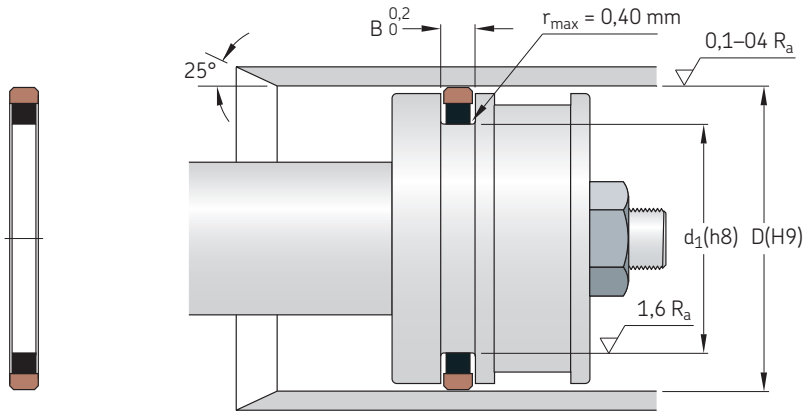

Dimensions			Series	Square ring size	Designation	Dimensions			Series	Square ring size	Designation
D	d ₁	B				D	d ₁	B			
mm			-	-	-	mm			-	-	-
50	40	4,5	A	-222	MPS-A-050,0-PRS	190	168	11	D	-439	MPS-D-190,0-PRS
55	45	4,5	A	-224	MPS-A-055,0-PRS	200	178	11	D	-441	MPS-D-200,0-PRS
56	46	4,5	A	-224	MPS-A-056,0-PRS	204	182	11	D	-441	MPS-D-204,0-PRS
60	50	4,5	A	-225	MPS-A-060,0-PRS	210	188	11	D	-442	MPS-D-210,0-PRS
63	48	7,5	B	-328	MPS-B-063,0-PRS	220	198	11	D	-444	MPS-D-220,0-PRS
65	50	7,5	B	-329	MPS-B-065,0-PRS	224	202	11	D	-444	MPS-D-224,0-PRS
70	55	7,5	B	-330	MPS-B-070,0-PRS	225	203	11	D	-444	MPS-D-225,0-PRS
75	60	7,5	B	-332	MPS-B-075,0-PRS	230	208	11	D	-445	MPS-D-230,0-PRS
80	65	7,5	B	-333	MPS-B-080,0-PRS	240	218	11	D	-446	MPS-D-240,0-PRS
85	70	7,5	B	-335	MPS-B-085,0-PRS						
90	75	7,5	B	-336	MPS-B-090,0-PRS						
95	80	7,5	B	-338	MPS-B-095,0-PRS						
100	85	7,5	B	-340	MPS-B-100,0-PRS						
110	94	7,5	C	-342	MPS-C-110,0-PRS						
112	96	7,5	C	-343	MPS-C-112,0-PRS						
116	100	7,5	C	-344	MPS-C-116,0-PRS						
118	102	7,5	C	-345	MPS-C-118,0-PRS						
120	104	7,5	C	-346	MPS-C-120,0-PRS						
125	109	7,5	C	-347	MPS-C-125,0-PRS						
130	114	7,5	C	-349	MPS-C-130,0-PRS						
140	124	7,5	C	-352	MPS-C-140,0-PRS						
150	134	7,5	C	-355	MPS-C-150,0-PRS						
160	144	7,5	C	-358	MPS-C-160,0-PRS						
170	148	11	D	-435	MPS-D-170,0-PRS						
180	158	11	D	-438	MPS-D-180,0-PRS						

Crown piston seal

Crown Seals are double acting piston seals that are designed to fit in to O-ring grooves on piston applications.

The Crown Seal is a squeeze-type seal. An O-ring is used as a loading spring and to seal the static surface. The crowned sealing surface produces a positive seal from vacuum to high pressure, due to a narrow single line seal contact area. Crown Seal side legs act as an anti-extrusion device for the O-ring as well as adding stability to the seal. The dynamic sealing element of the Crown Seal can be made of either Lubrithane or Fluorotrel to give long life on relatively rough sealing surfaces.

Being bi-directional, they are also used frequently in slow speed rotary service.

Part number descriptions

Metric example

Metric-sized crown piston seals are designated by MPS at the start of the part number followed by the groove diameter, bore diameter and then style of Crown Seal.

MPS-022-028-CPV

Inch example

Inch-sized Crown Seals are designated by type and then O-ring groove dash number.

CPV-222

Product tables

See **page 53** for metric sized and **page 54** for inch sized products.

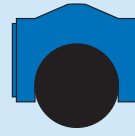

Operational range		Recommended material
Crown seal – Medium duty cycle		
Pressure:	350 bar (5 000 psi)	U-1003 Lubrithane 100 °C (212 °F)
Temperature:	-40 to +120 °C (-40 to +248 °F)	U-1023 HP Lubrithane (→ page 8)
Velocity:	1,0 m/s max (3 ft./s max)	F-1504 Fluorotrel
Surface finish:	R _a 0,1 to 0,4 μm (4 to 16 μin.)	
Extrusion gap	Pressure 70 °C (158 °F)	90 °C (194 °F)
mm (in.)	bar (psi)	bar (psi)
Extrusion gaps U-1003		
0,10 (0.004)	345 (5 000)	275 (4 000)
0,15 (0.006)	345 (5 000)	225 (3 300)
0,20 (0.008)	310 (4 500)	170 (2 500)

Crown piston seals – metric sizes

D 28 – 230 mm

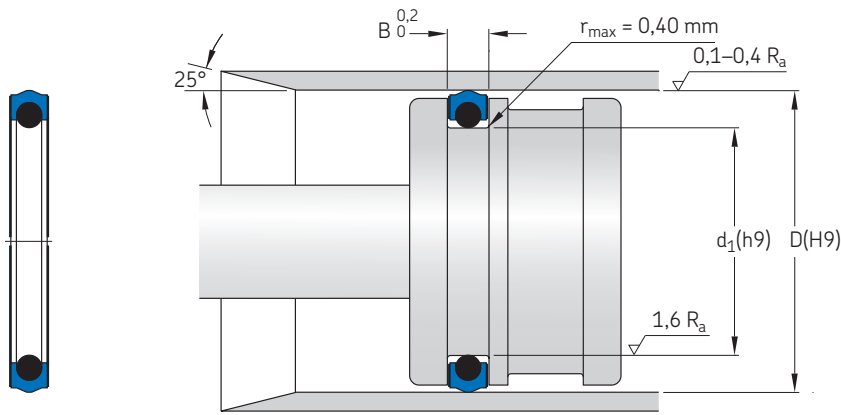

Dimensions					Designation	Dimensions					Designation
Cylinder bore D	Bore tolerance +/-	Groove diameter d ₁	tolerance +/-	Groove length B		Cylinder bore D	Bore tolerance +/-	Groove diameter d ₁	tolerance +/-	Groove length B	
mm					-	mm					-
28	+0,08/0	22,00	0/-0,08	4,70	MPS-022-028-CPV	120	+0,10/0	110,00	0/-0,10	7,50	MPS-110-120-CPV
30	+0,08/0	24,00	0/-0,08	4,70	MPS-024-030-CPV	125	+0,10/0	115,00	0/-0,10	7,50	MPS-115-125-CPV
32	+0,08/0	26,00	0/-0,08	4,70	MPS-026-032-CPV	130	+0,10/0	120,00	0/-0,10	7,50	MPS-120-130-CPV
35	+0,08/0	29,00	0/-0,08	4,70	MPS-029-035-CPV	135	+0,10/0	125,00	0/-0,10	7,50	MPS-125-135-CPV
38	+0,08/0	32,00	0/-0,08	4,70	MPS-032-038-CPV	140	+0,10/0	130,00	0/-0,10	7,50	MPS-130-140-CPV
40	+0,08/0	34,00	0/-0,08	4,70	MPS-034-040-CPV	145	+0,10/0	135,00	0/-0,10	7,50	MPS-135-145-CPV
42	+0,08/0	36,00	0/-0,08	4,70	MPS-036-042-CPV	150	+0,10/0	140,00	0/-0,10	7,50	MPS-140-150-CPV
45	+0,08/0	39,00	0/-0,08	4,70	MPS-039-045-CPV	155	+0,10/0	140,00	0/-0,10	11,00	MPS-140-155-CPV
48	+0,08/0	42,00	0/-0,08	4,70	MPS-042-048-CPV	160	+0,10/0	145,00	0/-0,10	11,00	MPS-145-160-CPV
50	+0,08/0	44,00	0/-0,08	4,70	MPS-044-050-CPV	165	+0,10/0	150,00	0/-0,10	11,00	MPS-150-165-CPV
52	+0,10/0	42,00	0/-0,10	7,50	MPS-042-052-CPV	170	+0,10/0	155,00	0/-0,10	11,00	MPS-155-170-CPV
55	+0,10/0	45,00	0/-0,10	7,50	MPS-045-055-CPV	175	+0,10/0	160,00	0/-0,10	11,00	MPS-160-175-CPV
60	+0,10/0	50,00	0/-0,10	7,50	MPS-050-060-CPV	180	+0,10/0	165,00	0/-0,10	11,00	MPS-165-180-CPV
63	+0,10/0	53,00	0/-0,10	7,50	MPS-053-063-CPV	185	+0,10/0	170,00	0/-0,10	11,00	MPS-170-185-CPV
65	+0,10/0	55,00	0/-0,10	7,50	MPS-055-065-CPV	190	+0,10/0	175,00	0/-0,10	11,00	MPS-175-190-CPV
70	+0,10/0	60,00	0/-0,10	7,50	MPS-060-070-CPV	195	+0,10/0	180,00	0/-0,10	11,00	MPS-180-195-CPV
75	+0,10/0	65,00	0/-0,10	7,50	MPS-065-075-CPV	200	+0,10/0	185,00	0/-0,10	11,00	MPS-185-200-CPV
80	+0,10/0	70,00	0/-0,10	7,50	MPS-070-080-CPV	205	+0,10/0	190,00	0/-0,10	11,00	MPS-190-205-CPV
85	+0,10/0	75,00	0/-0,10	7,50	MPS-075-085-CPV	210	+0,10/0	195,00	0/-0,10	11,00	MPS-195-210-CPV
90	+0,10/0	80,00	0/-0,10	7,50	MPS-080-090-CPV	215	+0,10/0	200,00	0/-0,10	11,00	MPS-200-215-CPV
95	+0,10/0	85,00	0/-0,10	7,50	MPS-085-095-CPV	220	+0,10/0	205,00	0/-0,10	11,00	MPS-205-220-CPV
100	+0,10/0	90,00	0/-0,10	7,50	MPS-090-100-CPV	225	+0,10/0	210,00	0/-0,10	11,00	MPS-210-225-CPV
105	+0,10/0	95,00	0/-0,10	7,50	MPS-095-105-CPV	230	+0,10/0	215,00	0/-0,10	11,00	MPS-215-230-CPV
110	+0,10/0	100,00	0/-0,10	7,50	MPS-100-110-CPV						
115	+0,10/0	105,00	0/-0,10	7,50	MPS-105-115-CPV						

Crown piston seals – inch sizes

D 0.375 – 12.000 in

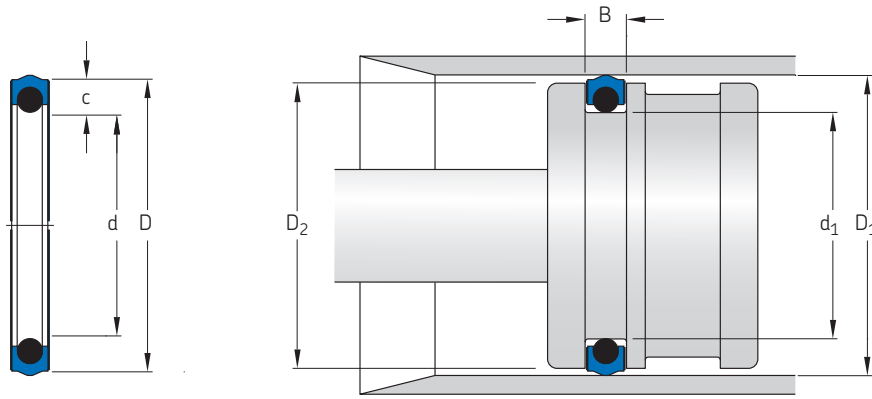

Nominal dimensions		Cross section c	Dimensions		Groove diameter		Groove length		Piston diameter		Designation
Outside diameter D	Inside diameter d		Bore diameter D ₁	tolerance +/-	d ₁	tolerance +/-	B	tolerance +/-	D ₂	tolerance +/-	
in.											
0.375	0.187	0.094	0.374	+0.002/-0	0.188	+0/-0.002	0.150	+0.005/-0	0.372	+0/-0.002	CPV-106
0.437	0.250	0.094	0.436	+0.002/-0	0.250	+0/-0.002	0.150	+0.005/-0	0.434	+0/-0.002	CPV-108
0.500	0.312	0.094	0.499	+0.002/-0	0.313	+0/-0.002	0.150	+0.005/-0	0.497	+0/-0.002	CPV-109
0.562	0.312	0.125	0.561	+0.002/-0	0.315	+0/-0.002	0.185	+0.005/-0	0.559	+0/-0.002	CPV-203
0.625	0.375	0.125	0.624	+0.002/-0	0.378	+0/-0.002	0.185	+0.005/-0	0.622	+0/-0.002	CPV-204
0.687	0.437	0.125	0.686	+0.002/-0	0.440	+0/-0.002	0.185	+0.005/-0	0.684	+0/-0.002	CPV-205
0.750	0.500	0.125	0.749	+0.002/-0	0.503	+0/-0.002	0.185	+0.005/-0	0.747	+0/-0.002	CPV-206
0.812	0.562	0.125	0.811	+0.002/-0	0.565	+0/-0.002	0.185	+0.005/-0	0.809	+0/-0.002	CPV-207
0.875	0.625	0.125	0.874	+0.002/-0	0.628	+0/-0.002	0.185	+0.005/-0	0.872	+0/-0.002	CPV-208
0.937	0.687	0.125	0.936	+0.002/-0	0.690	+0/-0.002	0.185	+0.005/-0	0.934	+0/-0.002	CPV-209
1.000	0.750	0.125	1.000	+0.002/-0	0.754	+0/-0.002	0.185	+0.005/-0	0.998	+0/-0.002	CPV-210
1.062	0.812	0.125	1.062	+0.002/-0	0.816	+0/-0.002	0.185	+0.005/-0	1.060	+0/-0.002	CPV-211
1.125	0.875	0.125	1.125	+0.002/-0	0.879	+0/-0.002	0.185	+0.005/-0	1.123	+0/-0.002	CPV-212
1.187	0.937	0.125	1.187	+0.002/-0	0.941	+0/-0.002	0.185	+0.005/-0	1.185	+0/-0.002	CPV-213
1.250	1.000	0.125	1.250	+0.002/-0	1.004	+0/-0.002	0.185	+0.005/-0	1.248	+0/-0.002	CPV-214
1.312	1.062	0.125	1.312	+0.002/-0	1.066	+0/-0.002	0.185	+0.005/-0	1.310	+0/-0.002	CPV-215
1.375	1.125	0.125	1.375	+0.002/-0	1.129	+0/-0.002	0.185	+0.005/-0	1.373	+0/-0.002	CPV-216
1.437	1.187	0.125	1.437	+0.002/-0	1.191	+0/-0.002	0.185	+0.005/-0	1.435	+0/-0.002	CPV-217
1.500	1.250	0.125	1.500	+0.002/-0	1.254	+0/-0.002	0.185	+0.005/-0	1.498	+0/-0.002	CPV-218
1.562	1.312	0.125	1.562	+0.002/-0	1.316	+0/-0.002	0.185	+0.005/-0	1.560	+0/-0.002	CPV-219
1.625	1.375	0.125	1.625	+0.002/-0	1.379	+0/-0.002	0.185	+0.005/-0	1.623	+0/-0.002	CPV-220
1.750	1.500	0.125	1.750	+0.002/-0	1.504	+0/-0.002	0.185	+0.005/-0	1.748	+0/-0.002	CPV-222
1.875	1.500	0.187	1.875	+0.002/-0	1.500	+0/-0.002	0.185	+0.005/-0	1.873	+0/-0.002	CPV-325
2.000	1.625	0.187	2.000	+0.002/-0	1.625	+0/-0.002	0.185	+0.005/-0	1.998	+0/-0.002	CPV-326
2.125	1.750	0.187	2.125	+0.002/-0	1.750	+0/-0.002	0.185	+0.005/-0	2.123	+0/-0.002	CPV-327
2.250	1.875	0.187	2.250	+0.002/-0	1.875	+0/-0.002	0.185	+0.005/-0	2.248	+0/-0.002	CPV-328
2.375	2.000	0.187	2.375	+0.002/-0	2.000	+0/-0.002	0.185	+0.005/-0	2.373	+0/-0.002	CPV-329
2.500	2.125	0.187	2.500	+0.002/-0	2.125	+0/-0.002	0.185	+0.005/-0	2.498	+0/-0.002	CPV-330
2.625	2.250	0.187	2.625	+0.002/-0	2.250	+0/-0.002	0.185	+0.005/-0	2.622	+0/-0.002	CPV-331
2.750	2.375	0.187	2.749	+0.004/-0	2.374	+0/-0.004	0.280	+0.005/-0	2.747	+0/-0.004	CPV-332
2.875	2.500	0.187	2.874	+0.004/-0	2.499	+0/-0.004	0.280	+0.005/-0	2.872	+0/-0.004	CPV-333
3.000	2.625	0.187	2.999	+0.004/-0	2.624	+0/-0.004	0.280	+0.005/-0	2.997	+0/-0.004	CPV-334
3.125	2.750	0.187	3.124	+0.004/-0	2.749	+0/-0.004	0.280	+0.005/-0	3.122	+0/-0.004	CPV-335
3.250	2.875	0.187	3.249	+0.004/-0	2.874	+0/-0.004	0.280	+0.005/-0	3.247	+0/-0.004	CPV-336
3.375	3.000	0.187	3.375	+0.004/-0	3.000	+0/-0.004	0.280	+0.005/-0	3.373	+0/-0.004	CPV-337
3.500	3.125	0.187	3.500	+0.004/-0	3.125	+0/-0.004	0.280	+0.005/-0	3.498	+0/-0.004	CPV-338
3.625	3.250	0.187	3.625	+0.004/-0	3.250	+0/-0.004	0.280	+0.005/-0	3.623	+0/-0.004	CPV-339

Nominal dimensions		Cross section c	Dimensions		Groove diameter		Groove length		Piston diameter		Designation
Outside diameter D	Inside diameter d		Bore diameter D ₁	tolerance +/-	diameter d ₁	tolerance +/-	length B	tolerance +/-	diameter D ₂	tolerance +/-	
in.											
3.750	3.375	0.187	3.750	+0.004/-0	3.375	+0/-0.004	0.280	+0.005/-0	3.748	+0/-0.004	CPV-340
3.875	3.500	0.187	3.875	+0.004/-0	3.500	+0/-0.004	0.280	+0.005/-0	3.873	+0/-0.004	CPV-341
4.000	3.625	0.187	4.000	+0.004/-0	3.625	+0/-0.004	0.280	+0.005/-0	3.998	+0/-0.004	CPV-342
4.125	3.750	0.187	4.125	+0.004/-0	3.750	+0/-0.004	0.280	+0.005/-0	4.123	+0/-0.004	CPV-343
4.250	3.875	0.187	4.250	+0.004/-0	3.875	+0/-0.004	0.280	+0.005/-0	4.248	+0/-0.004	CPV-344
4.375	4.000	0.187	4.375	+0.004/-0	4.000	+0/-0.004	0.280	+0.005/-0	4.373	+0/-0.004	CPV-345
4.500	4.125	0.187	4.500	+0.004/-0	4.125	+0/-0.004	0.280	+0.005/-0	4.498	+0/-0.004	CPV-346
4.625	4.250	0.187	4.625	+0.004/-0	4.250	+0/-0.004	0.280	+0.005/-0	4.623	+0/-0.004	CPV-347
4.750	4.375	0.187	4.750	+0.004/-0	4.375	+0/-0.004	0.280	+0.005/-0	4.748	+0/-0.004	CPV-348
4.875	4.500	0.187	4.875	+0.004/-0	4.500	+0/-0.004	0.280	+0.005/-0	4.873	+0/-0.004	CPV-349
5.000	4.625	0.187	5.001	+0.004/-0	4.626	+0/-0.004	0.280	+0.005/-0	4.999	+0/-0.004	CPV-350
5.125	4.625	0.125	5.125	+0.004/-0	4.646	+0/-0.004	0.365	+0.006/-0	5.124	+0/-0.004	CPV-426
5.250	4.750	0.125	5.251	+0.004/-0	4.770	+0/-0.004	0.365	+0.006/-0	5.249	+0/-0.004	CPV-427
5.375	4.875	0.125	5.376	+0.004/-0	4.896	+0/-0.004	0.365	+0.006/-0	5.374	+0/-0.004	CPV-428
5.500	5.000	0.125	5.501	+0.004/-0	5.021	+0/-0.004	0.365	+0.006/-0	4.499	+0/-0.004	CPV-429
5.625	5.125	0.125	5.626	+0.004/-0	5.146	+0/-0.004	0.365	+0.006/-0	5.624	+0/-0.004	CPV-430
5.750	5.250	0.125	5.751	+0.004/-0	5.271	+0/-0.004	0.365	+0.006/-0	5.749	+0/-0.004	CPV-431
5.875	5.375	0.125	5.876	+0.004/-0	5.396	+0/-0.004	0.365	+0.006/-0	5.874	+0/-0.004	CPV-432
6.000	5.500	0.125	6.001	+0.004/-0	5.521	+0/-0.004	0.365	+0.006/-0	5.999	+0/-0.004	CPV-433
6.125	5.625	0.125	6.126	+0.004/-0	5.646	+0/-0.004	0.365	+0.006/-0	6.124	+0/-0.004	CPV-434
6.250	5.750	0.125	6.251	+0.004/-0	5.771	+0/-0.004	0.365	+0.006/-0	6.249	+0/-0.004	CPV-435
6.500	6.000	0.125	6.500	+0.006/-0	6.020	+0/-0.006	0.365	+0.006/-0	6.498	+0/-0.006	CPV-437
6.750	6.250	0.125	6.750	+0.006/-0	6.270	+0/-0.006	0.365	+0.006/-0	6.748	+0/-0.006	CPV-438
7.000	6.500	0.125	7.000	+0.006/-0	6.520	+0/-0.006	0.365	+0.006/-0	6.998	+0/-0.006	CPV-439
7.250	6.750	0.125	7.250	+0.006/-0	6.770	+0/-0.006	0.365	+0.006/-0	7.248	+0/-0.006	CPV-440
7.500	7.000	0.125	7.500	+0.006/-0	7.020	+0/-0.006	0.365	+0.006/-0	7.498	+0/-0.006	CPV-441
7.750	7.250	0.125	7.750	+0.006/-0	7.270	+0/-0.006	0.365	+0.006/-0	7.748	+0/-0.006	CPV-442
8.000	7.500	0.125	8.000	+0.006/-0	7.520	+0/-0.006	0.365	+0.006/-0	7.998	+0/-0.006	CPV-443
8.125	7.750	0.125	8.250	+0.006/-0	7.770	+0/-0.006	0.365	+0.006/-0	8.248	+0/-0.006	CPV-444
8.500	8.000	0.125	8.500	+0.006/-0	8.020	+0/-0.006	0.365	+0.006/-0	8.498	+0/-0.006	CPV-445
9.000	8.500	0.125	9.000	+0.006/-0	8.520	+0/-0.006	0.365	+0.006/-0	8.998	+0/-0.006	CPV-446
9.500	9.000	0.125	9.500	+0.006/-0	9.020	+0/-0.006	0.365	+0.006/-0	9.498	+0/-0.006	CPV-447
10.000	9.500	0.125	10	+0.006/-0	9.520	+0/-0.006	0.365	+0.006/-0	9.998	+0/-0.006	CPV-448
10.500	10.000	0.125	10.500	+0.006/-0	10.020	+0/-0.006	0.365	+0.006/-0	10.498	+0/-0.006	CPV-449
11.000	10.500	0.125	11.000	+0.006/-0	10.520	+0/-0.006	0.365	+0.006/-0	10.998	+0/-0.006	CPV-450
11.500	11.000	0.125	11.500	+0.006/-0	11.020	+0/-0.006	0.365	+0.006/-0	11.498	+0/-0.006	CPV-451
12.000	11.500	0.125	12.000	+0.006/-0	11.520	+0/-0.006	0.365	+0.006/-0	11.998	+0/-0.006	CPV-452

Locking T Seals

The T Seal can replace conventional T Seals in any piston T Seal application. The LTP style seal is available in the same selection of materials for use in a wide variety of fluids and service recommendations. The LTP Seal is designed to retrofit standard, -1 and -2 O-ring, T Seal and Crown Seal grooves. The LTP Seal provides all of the benefits of a T Seal, plus adds a locking backup which locks the backup in to the T Seal element, a net molded dynamic sealing surface and outboard corner chamfer on the backup components.

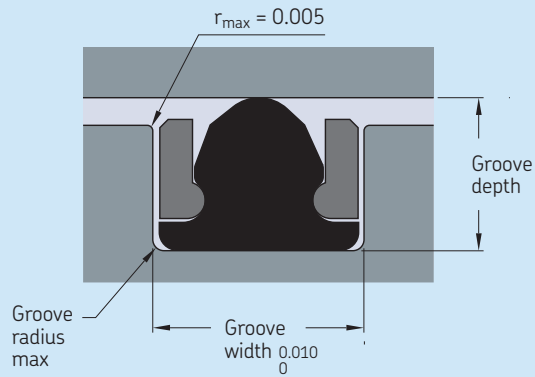

T seal part numbering system

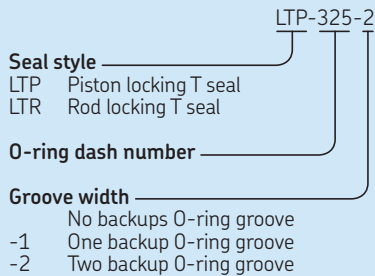

T seal groove dimensions

O-ring series	Groove depth	Groove width			Groove radius
		-	-1	-2	
-	in.	in.			in.
-100	0.093 ref.	0.150	0.183	0.245	0.015
-200	0.122 ref.	0.185	0.235	0.304	0.032
-300	0.187 ref.	0.280	0.334	0.424	0.032
-400	0.240 ref.	0.366	0.475	0.579	0.032

T seal standard materials

Material	Application recommendation	Temperature range			
		from	to	from	to
-	-	°C		°F	

Seal materials

Nitriles (NBR)					
Nitrile 70A, A-8501	Standard nitrile for most fluids.	-37	129	-35	+265
Nitrile 70A, A-8504	Low temperature nitrile for most fluids.	-54	116	-65	+240
Carboxylated nitrile 70A, C-7001	Carboxylated nitrile for most fluids. Improved wear properties.	-18	135	0	+275
HNBR 75A, C-7021	Hydrogenated nitrile for extreme wear and better fluid resistance.	-46	160	-50	+320

Fluorocarbon (FKM)

Poly VI 70A, V-7501	Fluorocarbon rubber for applications requiring improved fluid resistance.	-29	+204	-20	+400
Poly VI 70A, V-7510	Fluorocarbon rubber for applications requiring improved fluid resistance. Peroxide cured Terpolymer for the most severe fluids.	-29	+204	-20	+400

Ethylene Propylene (EPR)

EPR 70A, E-8001	EPR/EPDM rubber for phosphate ester and water/water glycol fluids. Not recommended for applications where mineral oils may be present.	-54	149	-65	+300
-----------------	---	-----	-----	-----	------

Backup ring materials

Nylon, P-2506 or #707	Nylon for most standard fluid power applications. Not recommended for applications where water may be present	-54	149	-65	+300
PTFE, #700	PTFE for low pressure applications, where low friction is required, or nylon can not be used.				
PTFE, #745	PEEK for extreme high pressure / high temperature applications.				
P-2548/775	Acetal for most standard water based fluid applications.	-40	+121	-40	+250

LTP seals

Piston diameter is equal to bore diameter (A), minus (Maximum diameter clearance) for specific bore size range.

For sizes not listed, contact SKF Polyseal for technical assistance.

Standard material consists of a 70 Shore A nitrile seal element and tough extrusion resistant nylon anti-extrusion ring, designed specifically for hydraulic and pneumatic service. Other materials are available upon request.

Product tables

See **page 56** for LTP seals product table.

Piston clearance limits

Bore size range		Maximum diameter clearance
from	to	
in.	–	in.
0.250	0.500	0.004
0.501	1.750	0.005
1.751	4.875	0.007
4.876	9.000	0.009
9.001		0.010

LTP seals
D 0.562 – 15.500 in.

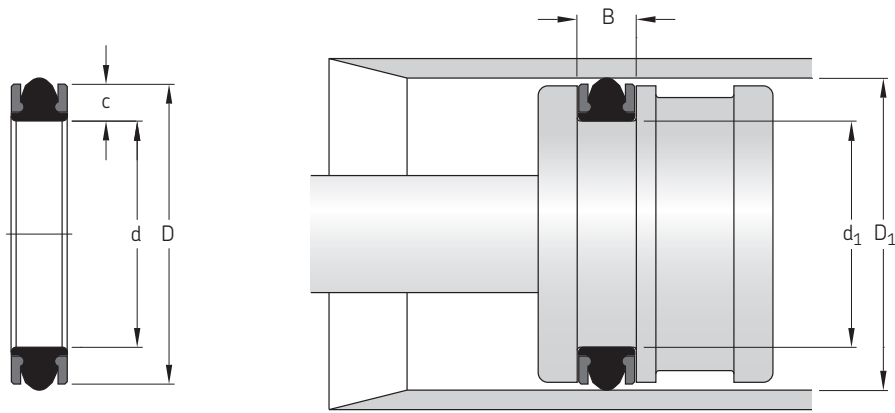

Nominal dimensions		Cross section c	Dimensions			Designation
Outside diameter D	Inside diameter d		Bore diameter D ₁	Groove diameter d ₁	Groove length B	
in.						
		Tolerance	+0.001 +0.000	+0.002 -0.000	+0.010 -0.000	
0.562	0.312	0.125	0.562	0.317	0.185	LTP-203
0.625	0.375	0.125	0.625	0.380	0.185	LTP-204
0.687	0.437	0.125	0.687	0.442	0.185	LTP-205
0.750	0.500	0.125	0.750	0.505	0.185	LTP-206
0.812	0.562	0.125	0.812	0.567	0.185	LTP-207
0.875	0.625	0.125	0.875	0.630	0.185	LTP-208
1.312	0.687	0.125	0.937	0.692	0.185	LTP-209
1.000	0.750	0.125	1.001	0.756	0.185	LTP-210
1.062	0.812	0.125	1.063	0.818	0.185	LTP-211
1.125	0.875	0.125	1.126	0.881	0.185	LTP-212
1.812	1.312	0.125	1.188	0.943	0.185	LTP-213
1.250	1.000	0.125	1.251	1.006	0.185	LTP-214
1.312	1.062	0.125	1.313	1.068	0.185	LTP-215
1.375	1.125	0.125	1.376	1.131	0.185	LTP-216
1.437	1.187	0.125	1.438	1.193	0.185	LTP-217
1.500	1.250	0.125	1.501	1.256	0.185	LTP-218
1.562	1.312	0.125	1.563	1.318	0.185	LTP-219
1.625	1.375	0.125	1.626	1.381	0.185	LTP-220
1.687	1.437	0.125	1.688	1.442	0.185	LTP-221
1.750	1.500	0.125	1.751	1.506	0.185	LTP-222
1.875	1.500		1.876	1.502	0.280	LTP-325
2.000	1.625	0.187	2.001	1.627	0.280	LTP-326
2.125	1.750	0.187	2.126	1.752	0.280	LTP-327
2.250	1.875	0.187	2.251	1.877	0.280	LTP-328
2.375	2.000	0.187	2.376	2.002	0.280	LTP-329
2.500	2.125	0.187	2.501	2.127	0.280	LTP-330
2.625	2.250	0.187	2.626	2.252	0.280	LTP-331

Nominal dimensions		Cross section c	Dimensions		Groove length B	Designation
Outside diameter D	Inside diameter d		Bore diameter D ₁	Groove diameter d ₁		
in.						
			Tolerance	+0.002 -0.002	+0.003 -0.001	+0.010 -0.000
2.750	2.375	0.187	2.751	2.377	0.280	LTP-332
2.875	2.500	0.187	2.876	2.502	0.280	LTP-333
3.000	2.625	0.187	3.001	2.627	0.280	LTP-334
3.125	2.750	0.187	3.126	2.752	0.280	LTP-335
3.250	2.875	0.187	3.251	2.877	0.280	LTP-336
3.375	3.000	0.187	3.377	3.003	0.280	LTP-337
3.500	3.125	0.187	3.502	3.128	0.280	LTP-338
3.625	3.250	0.187	3.627	3.253	0.280	LTP-339
3.750	3.375	0.187	3.752	3.378	0.280	LTP-340
3.875	3.500	0.187	3.877	3.503	0.280	LTP-341
4.000	3.625	0.187	4.002	3.628	0.280	LTP-342
4.125	3.750	0.187	4.127	3.753	0.280	LTP-343
4.250	3.875	0.187	4.252	3.878	0.280	LTP-344
4.375	4.000	0.187	4.377	4.003	0.280	LTP-345
4.500	4.125	0.187	4.502	4.128	0.280	LTP-346
4.625	4.250	0.187	4.627	4.253	0.280	LTP-347
4.750	4.375	0.187	4.752	4.378	0.280	LTP-348
4.875	4.500	0.187	4.877	4.503	0.280	LTP-349
5.000	4.625	0.187	5.003	4.629	0.280	LTP-350
5.125	4.625	0.250	5.128	4.649	0.366	LTP-426
5.250	4.750	0.250	5.253	4.774	0.366	LTP-427
5.375	4.875	0.250	5.378	4.899	0.366	LTP-428
5.500	5.000	0.250	5.503	5.024	0.366	LTP-429
5.625	5.125	0.250	5.628	5.149	0.366	LTP-430
5.750	5.250	0.250	5.753	5.274	0.366	LTP-431
5.875	5.375	0.250	5.878	5.399	0.366	LTP-432
6.000	5.500	0.250	6.003	5.524	0.366	LTP-433
6.125	5.375	0.250	6.128	5.649	0.366	LTP-434
6.250	5.750	0.250	6.253	5.774	0.366	LTP-435
			Tolerance	+0.003 -0.003	+0.004 -0.002	+0.010 -0.000
6.375	5.875	0.250	6.378	5.899	0.366	LTP-436
6.500	6.000	0.250	6.503	6.024	0.366	LTP-437
6.750	6.250	0.250	6.753	6.274	0.366	LTP-438
7.000	6.500	0.250	7.003	6.524	0.366	LTP-439
7.250	6.750	0.250	7.253	6.774	0.366	LTP-440
7.500	7.000	0.250	7.503	7.024	0.366	LTP-441
7.750	7.250	0.250	7.753	7.274	0.366	LTP-442
8.000	7.500	0.250	8.003	7.524	0.366	LTP-443
8.250	7.750	0.250	8.253	7.774	0.366	LTP-444
8.500	8.000	0.250	8.503	8.024	0.366	LTP-445
9.000	8.500	0.250	9.003	8.524	0.366	LTP-446
9.500	9.000	0.250	9.503	9.024	0.366	LTP-447
10.000	9.500	0.250	10.003	9.524	0.366	LTP-448
10.500	10.000	0.250	10.503	10.024	0.366	LTP-449
11.000	10.500	0.250	11.003	10.524	0.366	LTP-450
11.500	11.000	0.250	11.503	11.204	0.366	LTP-451
12.000	11.500	0.250	12.003	11.524	0.366	LTP-452
12.500	12.000	0.250	12.503	12.024	0.366	LTP-453
13.000	12.500	0.250	13.003	12.524	0.366	LTP-454
13.500	13.000	0.250	13.503	13.024	0.366	LTP-455
14.000	13.500	0.250	14.003	13.524	0.366	LTP-456
15.500	15.000	0.250	15.503	15.024	0.366	LTP-459

Polyurethane piston seals

Part number descriptions

Metric example

Metric-sized polyurethane piston cups are designated by MPS at the start of the part number followed by inside diameter, outside diameter, height and then U Cup designation.

MPS-016-024-05,8 UNP

Inch example:

Inch-sized U Cups are designated by U Cup designation, cross section of the seal, then I.D., and then height.

UNP 125-00.125-250

Part numbers for piston seals

Metric example

Metric-sized polyurethane piston seals are designated by MPS at the start of the part number followed by inside diameter, outside diameter, height and then rod seal type.

MPS-016-024-05,8 DP

Inch example

Inch-sized polyurethane piston seals are designated by cross section, seal inside diameter, height and then piston seal type.

125-00.125-250-DP

Product tables

See **page 62** for metric sized and **page 20** for inch sized products.

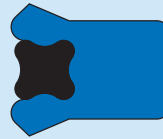

Type B

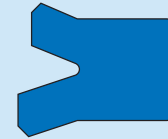

UNP

Operating range		Recommended material
UNP seal – High duty cycle		
Pressure:	400 bar max. (5 800 psi max.)	U-1023 HP Lubrithane
Temperature:	-40 to +120 °C (-40 to +248 °F)	U-1029 HP Lubrithane
Velocity:	1,0 m/s max. (3 ft./s max.)	U-1027 EXHP Lubrithane
Surface finish:	R _a 0,1 to 0,4 μm (4 to 16 μin.)	
Type B – High duty cycle		
Pressure:	400 bar max. (5 800 psi max.)	U-1003 Lubrithane 100 °C (212 °F)
Temperature:	-40 to +120 °C (-40 to +248 °F)	U-1023 HP Lubrithane
Velocity:	1,0 m/s max. (3 ft./s max.)	U-1029 HP Lubrithane
Surface finish:	R _a 0,1 to 0,4 μm (4 to 16 μin.)	F-1504 Fluorotrel
Extrusion gap	Pressure 70 °C (158 °F)	90 °C (194 °F)
mm (in.)	bar (psi)	bar (psi)
Extrusion gaps U-1003		
0,10 (0.004)	345 (5 000)	275 (4 000)
0,15 (0.006)	345 (5 000)	225 (3 300)
0,20 (0.008)	310 (4 500)	170 (2 500)
Extrusion gaps U-1003/Nylon		
0,10 (0.004)	690 (10 000)	690 (10 000)
0,15 (0.006)	690 (10 000)	690 (10 000)
0,20 (0.008)	690 (10 000)	690 (10 000)
Pressure w/wear guides U-1003/Nylon		
0,25 (0.010)	690 (10 000)	490 (7 000)
0,50 (0.020)	410 (6 000)	300 (4 400)
0,75 (0.030)	300 (4 400)	250 (3 600)

Polyurethane piston seals – metric sizes

D 19 – 200 mm

$b_1 = 2,0$ mm

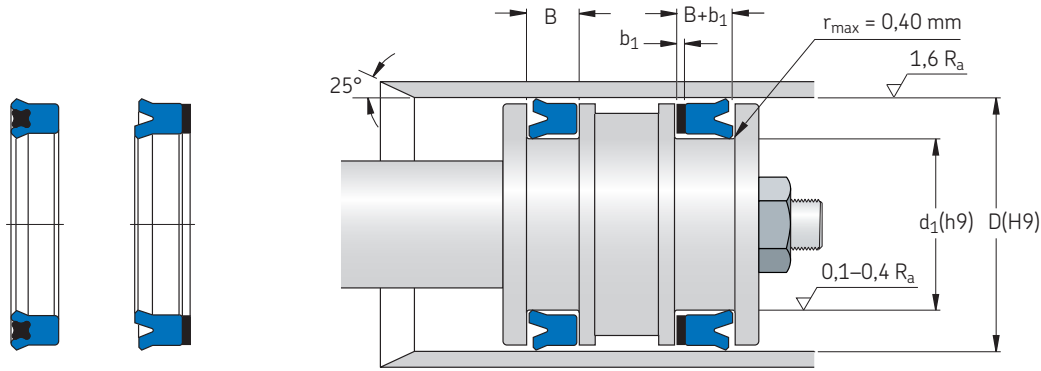

Nominal dimensions			Dimensions				Designation*
Outside diameter D	Inside diameter d_1	Height b	d_1	D	B	B+b ₁	
mm			mm				–
19	9	8,0	9,0	19,0	8,8	10,8	MPS-09-019-08,0 *
19,2	11,2	5,0	11,2	19,2	5,5	7,5	MPS-011,2-019,2-05,0 *
22	14	5,0	14,0	22,0	5,5	7,5	MPS-014-022-05,0 *
22,5	12,5	8,0	12,5	22,5	8,8	10,8	MPS-012,5-022,5-08,0 *
24	14	8,0	14,0	24,0	8,8	10,8	MPS-014-024-08,0 *
	16	5,0	16,0	24,0	5,5	7,5	MPS-016-024-05,0 *
25	15	8,0	15,0	25,0	8,8	10,8	MPS-015-025-08,0 *
26	16	8,0	16,0	26,0	8,8	10,8	MPS-016-026-08,0 *
	18	5,0	18,0	26,0	5,5	7,5	MPS-018-026-05,0 *
28	20	5,0	20,0	28,0	5,5	7,5	MPS-020-028-05,0 *
30	20	8,0	20,0	30,0	8,8	10,8	MPS-020-030-08,0 *
	22,4	5,0	22,4	30,0	5,5	7,5	MPS-022,4-030-05,0 *
33	25	5,0	25,0	33,0	5,5	7,5	MPS-025-033-05,0 *
35	25	8,0	25,0	35,0	8,8	10,8	MPS-025-035-08,0 *
40	28	10,0	28,0	40,0	11,0	13,0	MPS-028-040-10,0 *
	30	6,0	30,0	40,0	6,6	8,6	MPS-030-040-06,0 *
41,5	31,5	6,0	31,5	41,5	6,6	8,6	MPS-031,5-041,5-06,0 *
43	28	10,2	28,0	43,0	11,22	13,22	MPS-028-043-10,2 *
45	30	10,0	30,0	45,0	11,0	12,0	MPS-030-045-10,0 *
	35	6,0	35,0	45,0	6,6	8,6	MPS-035-045-06,0 *
50	35	10,0	35,0	50,0	11,0	13,0	MPS-035-050-10,0 *
	40	6,0	40,0	50,0	6,6	8,6	MPS-040-050-06,0 *
55	40	10,0	40,0	55,0	11,0	13,0	MPS-040-055-10,0 *
	45	6,0	45,0	55,0	6,6	8,6	MPS-045-055-06,0 *
56	45	7,0	45,0	56,0	7,7	9,7	MPS-045-056-07,0 *
60	45	10,0	45,0	60,0	11,0	13,0	MPS-045-060-10,0 *
	50	6,0	50,0	60,0	6,6	8,6	MPS-050-060-06,0 *

* Type B and UNP, depending on style.

Nominal dimensions			Dimensions				Designation*
Outside diameter D	Inside diameter d ₁	Height b	d ₁	D	B	B+b ₁	
mm			mm				–
63	48	10,0	48,0	63,0	11,0	13,0	MPS-048-063-10,0 *
	53	6,0	53,0	63,0	6,6	8,6	MPS-053-063-06,0 *
65	50	10,0	50,0	65,0	11,0	12,0	MPS-050-065-10,0 *
	55	6,0	55,0	65,0	6,6	8,6	MPS-055-065-06,0 *
66	56	6,0	56,0	66,0	6,6	8,6	MPS-056-066-06,0 *
70	60	6,0	60,0	70,0	6,6	8,6	MPS-060-070-06,0 *
75	55	12,0	55,0	75,0	13,2	15,2	MPS-055-075-12,0 *
	65	6,0	65,0	75,0	6,6	8,6	MPS-065-075-06,0 *
77	67	6,0	67,0	77,0	6,6	8,6	MPS-067-077-06,0 *
80	60	12,0	60,0	80,0	13,2	15,2	MPS-060-080-12,0 *
	70	6,0	70,0	80,0	6,6	8,6	MPS-070-080-06,0 *
85	65	12,0	65,0	85,0	13,2	15,2	MPS-065-085-12,0 *
90	70	12,0	70,0	90,0	13,2	15,2	MPS-070-090-12,0 *
	80	6,0	80,0	90,0	6,6	8,6	MPS-080-090-06,0 *
100	80	12,0	80,0	100,0	13,2	15,2	MPS-080-100-12,0 *
	85	9,0	85,0	100,0	9,9	11,9	MPS-085-100-09,0 *
105	90	9,0	90,0	105,0	9,9	11,9	MPS-090-105-09,0 *
110	90	12,0	90,0	110,0	13,2	15,2	MPS-090-110-12,0 *
	95	9,0	95,0	110,0	9,9	11,9	MPS-095-110-09,0 *
115	100	9,0	100,0	115,0	9,9	11,9	MPS-100-115-09,0 *
120	100	12,0	100,0	120,0	13,2	15,2	MPS-100-120-12,0 *
125	110	9,0	110,0	125,0	9,9	11,9	MPS-110-125-09,0 *
130	110	15,0	110,0	130,0	16,5	18,5	MPS-110-130-15,0 *
140	120	15,0	120,0	140,0	16,5	18,5	MPS-120-140-15,0 *
	125	9,0	125,0	140,0	9,9	11,9	MPS-125-140-09,0 *
145	125	15,0	125,0	145,0	16,5	18,5	MPS-125-145-15,0 *
150	130	15,0	130,0	150,0	16,5	11,5	MPS-130-150-15,0 *
	136	9,0	136,0	150,0	9,9	11,9	MPS-136-150-09,0 *
155	140	9,0	140,0	155,0	9,9	11,9	MPS-140-155-09,0 *
160	140	15,0	140,0	160,0	16,5	18,5	MPS-140-160-15,0 *
	145	16,0	145,0	160,0	17,6	19,6	MPS-145-160-16,0 *
170	150	15,0	150,0	170,0	16,5	18,5	MPS-150-170-15,0 *
180	155	16,0	155,0	180,0	17,6	19,6	MPS-155-180-16,0 *
	165	9,0	165,0	180,0	9,9	11,9	MPS-165-180-09,0 *
185	160	16,0	160,0	185,0	17,6	19,6	MPS-160-185-16,0 *
190	165	16,0	165,0	190,0	17,6	19,6	MPS-165-190-16,0 *
195	170	16,0	170,0	195,0	17,6	19,6	MPS-170-195-16,0 *
200	175	16,0	175,0	200,0	17,6	19,6	MPS-175-200-16,0 *
	180	12,5	180,0	200,0	13,75	15,75	MPS-180-200-12,5 *

* Type B and UNP, depending on style.

Polyurethane piston seals – metric sizes

D 205 – 330 mm

$b_1 = 2,0$ mm

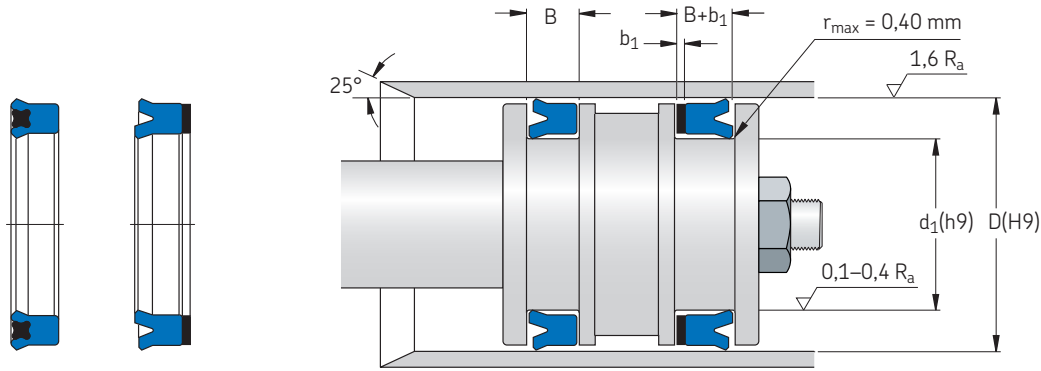

Nominal dimensions			Dimensions				Designation*
Outside diameter D	Inside diameter d_1	Height b	d_1	D	B	$B+b_1$	
mm			mm				–
205	180	16,0	180,0	205,0	17,6	19,6	MPS-180-205-16,0 *
215	190	16,0	190,0	215,0	17,6	19,6	MPS-190-215-16,0 *
220	200	12,5	200,0	220,0	13,75	15,75	MPS-200,220-12,5 *
224	204	12,5	204,0	224,0	13,75	15,75	MPS-204-224-12,5 *
225	200	16,0	200,0	225,0	17,6	19,6	MPS-200-225-16,0 *
237	212	19,0	212,0	237,0	20,9	22,9	MPS-212-237-19,0 *
249	224	19,0	224,0	249,0	20,9	22,9	MPS-224-249-19,0 *
250	225	19,0	225,0	250,0	20,9	22,9	MPS-225-250-19,0 *
	230	12,5	230,0	250,0	13,75	15,75	MPS-230-250-12,5 *
255	230	19,0	230,0	255,0	20,9	22,9	MPS-230-255-19,0 *
261	236	19,0	236,0	261,0	20,9	22,9	MPS-236-261-19,0 *
275	250	19,0	250,0	275,0	20,9	22,9	MPS-250-275-19,0 *
295	265	19,0	265,0	295,0	20,9	22,9	MPS-265-295-19,0 *
300	270	19,0	270,0	300,0	20,9	22,9	MPS-270-300-19,0 *
310	280	19,0	280,0	310,0	20,9	22,9	MPS-280-310-19,0 *
330	300	19,0	300,0	330,0	20,9	22,9	MPS-300-330-19,0 *

For inch sizes, see page 20 in this catalogue.

* Type B and UNP, depending on style.

Grooved piston rings

Part number descriptions

Metric example

Metric-sized grooved piston rings are designated by MPS at the start of the part number followed by the series cross section, bore diameter, a grooved piston ring designator and then material.

MPS-B-020,0-GPR-702

Inch example

Inch-sized grooved piston rings are designated by type and series, bore diameter, cut style, other feature (if available) and then material.

AP-404500-L-S-702

Product tables

See **page 68** for metric sized and **page 69** for inch sized products.

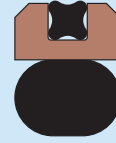

Operational range

Grooved piston seal – High speed
 Pressure: 350 bar max. (5 000 psi max.)
 Temperature: -40 to +200 °C (-40 to +212 °F)
 Velocity: 0,5 m/s max. (1.5 ft./s max.)
 Surface finish: R_a 0,1 to 0,3 μm (4 to 12 μin.)

Recommended material

741 – 40% bronzed filled PTFE
 Customer supplied O-ring and quad ring required

Maximum extrusion gaps

Series	0–100 bar	200 bar	400 bar
–	mm	mm	mm
B	0,46	0,15	0,10
C	0,61	0,20	0,13
D	0,76	0,25	0,15

Materials number	Description	Recommended service
702	15% glass, 5% moly filled PTFE	General purpose
716	15% graphite filled PTFE	Low friction
741	40% bronze filled PTFE	General purpose
711	25% carbon graphite filled PTFE	High temperature and high pressures

Note: Elastomer components required. Contact your SKF Polyseal Channel partner.

Part numbering guide

Type	Series d [in.]	Seal diameter	Seal cap material*
AP	- 4	06000	- 741 - A8501
AP – grooved piston seal ring	2 = 0.125 3 = 0.187 4 = 0.250 5 = 0.250 extended	5 digits for bore diameter 06000 = Ø 6.000 in.	Elastomer materials*
GP	- 4	06000	- 741 - N
GP – grooved piston seal ring	2 = 0.125 3 = 0.187 4 = 0.250 5 = 0.250 extended	5 digits for bore diameter 06000 = Ø 6.000 in.	Indicates vent notch (GP available with or without vent notch)

* See material specification.

AP and GP type piston rings are designed to provide a positive bi-directional fluid seal in applications requiring good sealability at low pressure differentials. They have been proven to be effective in piston accumulators and medium duty hydraulic cylinders.

AP and GP type piston rings

Series	Gland diameter	G	R max.	E maximum diametrical clearance		
				1 000 psi	3 000 psi	5 000 psi
–				in.		
2	Bore – 0.424	0.210/0.215	0.015	0.018	0.006	0.004
3	Bore – 0.616	0.288/0.293	0.025	0.024	0.008	0.005
4	Bore – 0.840	0.375/0.380	0.035	0.030	0.010	0.006
5	Bore – 0.920	0.375/0.380	0.035	0.030	0.010	0.006

Diameter tolerances

Bore			Gland		
dimension from	incl.	tolerance	dimension from	incl.	tolerance
in.			in.		
1.000	2.000	+0.003/–0	0.5	1.75	+0/–0.003
2.001	5.250	+0.004/–0	1.751	4.634	+0/–0.004
5.251	7.750	+0.005/–0	4.535	6.045	+0/–0.005
7.751	10.000	+0.006/–0	6.046	9.165	+0/–0.006
10.001	14.000	+0.008/–0	9.166	13.125	+0/–0.008

Grooved piston rings – metric sizes

D 20 – 190 mm

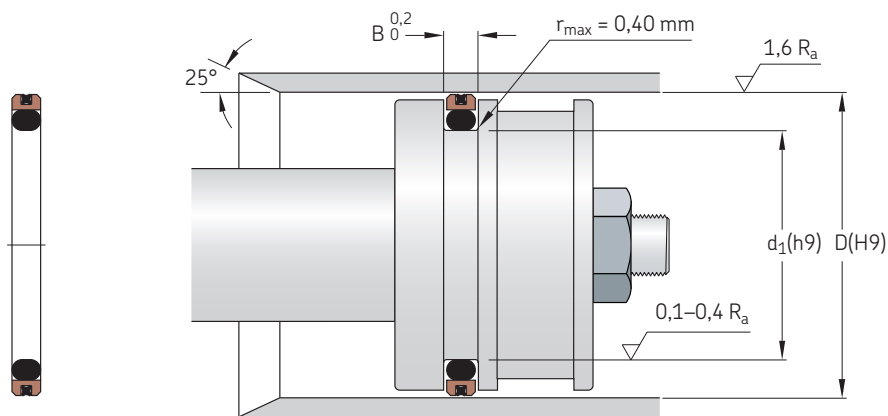

Dimensions						Designation							
D	d ₁	B	Loader size	Dynamic size	Series	Dimensions	Loader size	Dynamic size	Series	Designation			
mm	mm	mm	–	–	–	mm	–	–	–	–			
20	9	4,2	-204	4-016	B	MPS-B-020,0 APR	130	114,5	6,3	-348	4-158	C	MPS-C-130,0 APR
22	11	4,2	-205	4-018	B	MPS-B-022,0 APR	132	116,5	6,3	-349	4-159	C	MPS-C-132,0 APR
25	14	4,2	-207	4-020	B	MPS-B-025,0 APR	135	119,5	6,3	-350	4-159	C	MPS-C-135,0 APR
28	17	4,2	-209	4-022	B	MPS-B-028,0 APR	140	124,5	6,3	-352	4-160	C	MPS-C-140,0 APR
30	19	4,2	-210	4-023	B	MPS-B-030,0 APR	145	129,5	6,3	-353	4-161	C	MPS-C-145,0 APR
35	24	4,2	-213	4-026	B	MPS-B-035,0 APR	150	134,5	6,3	-355	4-161	C	MPS-C-150,0 APR
40	29	4,2	-216	4-028	B	MPS-B-040,0 APR	155	139,5	6,3	-356	4-162	D	MPS-C-155,0 APR
42	31	4,2	-217	4-029	B	MPS-B-042,0 APR	160	139	8,1	-432	4-258	D	MPS-D-160,0 APR
45	34	4,2	-219	4-030	B	MPS-B-045,0 APR	165	144	8,1	-434	4-259	D	MPS-D-165,0 APR
50	39	4,2	-222	4-031	B	MPS-B-050,0 APR	170	149	8,1	-435	4-259	D	MPS-D-170,0 APR
55	44	4,2	-224	4-033	B	MPS-B-055,0 APR	175	154	8,1	-437	4-260	D	MPS-D-175,0 APR
60	49	4,2	-225	4-034	B	MPS-B-060,0 APR	180	159	8,1	-438	4-261	D	MPS-D-180,0 APR
63	52	4,2	-226	4-035	B	MPS-B-063,0 APR	190	169	8,1	-439	4-262	D	MPS-D-190,0 APR
65	54	4,2	-227	4-036	B	MPS-B-065,0 APR							
70	59	4,2	-228	4-038	B	MPS-B-070,0 APR							
75	64	4,2	-230	4-039	B	MPS-B-075,0 APR							
80	69	4,2	-231	4-041	B	MPS-B-080,0 APR							
85	69,5	6,3	-335	4-151	C	MPS-C-085,0 APR							
90	74,5	6,3	-336	4-152	C	MPS-C-090,0 APR							
95	79,5	6,3	-338	4-153	C	MPS-C-095,0 APR							
100	84,5	6,3	-339	4-154	C	MPS-C-100,0 APR							
105	89,5	6,3	-341	4-154	C	MPS-C-105,0 APR							
110	94,5	6,3	-342	4-155	C	MPS-C-110,0 APR							
115	99,5	6,3	-344	4-156	C	MPS-C-115,0 APR							
120	104,5	6,3	-345	4-157	C	MPS-C-120,0 APR							
125	109,5	6,3	-347	4-157	C	MPS-C-125,0 APR							

Grooved piston rings – inch sizes

D 1.000 – 14.000 in.

Dimensions

Bore D	Series 2		Series 3	
	Loader	Dynamic	Loader	Dynamic

in.	–			
1.000	-207	-020		
1.125	-209	-022		
1.250	-211	-024		
1.375	-213	-026		
1.500	-215	-028		
1.625	-217	-029		
1.750	-219	-030		
1.875	-221	-031		
2.000	-222	-032	-324	-133
2.125			-325	-135
2.250			-326	-137
2.375			-327	-139
2.500			-328	-141
2.625			-329	-143
2.750			-330	-145
2.875			-331	-147
3.000			-332	-149
3.125			-333	-150
3.250			-334	-151
3.375			-335	-151
3.500			-336	-152
3.625			-337	-152
3.750			-338	-153
3.875			-339	-153
4.000			-340	-154
4.125			-341	-154
4.250			-342	-155
4.375			-343	-155
4.500			-344	-155
4.625			-345	-156
4.750			-346	-157
4.875			-347	-157
5.000			-348	-158
5.125			-349	-158
5.250			-350	-159

Dimensions

Bore D	Series 3		Series 4		Series 5	
	Loader	Dynamic	Loader	Dynamic	Loader	Dynamic

in.	–					
5.375	-351	-159	-425	-251		
5.500	-352	-160	-426	-252		
5.625	-353	-160	-427	-253		
5.750	-354	-161	-428	-254		
6.000	-356	-162	-430	-256		
6.250	-358	-163	-432	-258		
6.500	-360	-164	-434	-259		
6.750	-361	-165	-436	-260		
7.000	-362	-166	-437	-261		
7.250	-363	-167	-438	-262		
7.500	-364	-168	-439	-263		
7.750	-365	-169	-440	-264		
8.000	-366	-170	-441	-265		
8.250					-442	-266
8.500					-443	-267
8.750					-444	-268
9.000					-445	-269
9.250					-445	-270
9.500					-446	-271
9.750					-446	-272
10.000					-447	-273
10.500					-448	-274
11.000					-449	-275
11.500					-450	-276
12.000					-451	-277
12.500					-452	-278
13.000					-453	-278
13.500			-454	-279		
14.000			-455	-279		

Note: PTFE piston rings may require stretching for installation. Care must be taken to stretch PTFE rings without damaging them. Instructions for installation tools and recommendations are available. Please contact the SKF Polyseal engineering department for non-standard parts and any questions.

Capped T piston seal

Part number descriptions

Metric example

Metric-sized capped piston seals are designated by CT at the start of the part number, bore diameter, MK, cap material, energizer material and then backup material.

CT-A050M

Inch example:

Inch-sized capped piston seals are designated by CT at the start of the part number, series and then bore diameter.

CT-308000

Product tables

See **page 73** for metric sized.

Please contact SKF Polyseal for inch sizes.

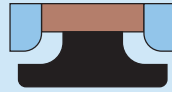

Capped T Seal

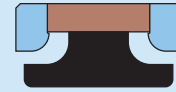

LCP

Operational range

Recommended material

Capped piston seal – High duty cycle

Pressure: 500 bar max. (7 251 psi max.)
 Temperature: -40 to +125 °C (-40 to +257 °F)
 Velocity: 1,0 m/s max (3 ft./s max.)
 Surface finish: R_a 0,1 to 0,4 μm (4 to 16 μin.)

702 – 15% glass, 5% moly filled PTFE
 741 – 40% bronze filled PTFE
 A-8501 nitrile
 P-2506 nylon

mm (in.)	bar (psi) @ 70 °C (158 °F)	bar (psi) @ 90 °C (194 °F)
----------	----------------------------	----------------------------

Extrusion gaps – Nylon

0,10 (0.004)	690 (10 000)	690 (10 000)
0,15 (0.006)	690 (10 000)	690 (10 000)
0,20 (0.008)	690 (10 000)	690 (10 000)

Pressure with wearguides – Nylon

0,25 (0.010)	690 (10 000)	490 (7 100)
0,50 (0.020)	410 (6 000)	300 (4 350)
0,75 (0.030)	300 (4 350)	250 (3 625)

Materials number	Description	Recommended service
702	15% glass, 5% moly filled PTFE	General purpose
716	15% graphite filled PTFE	Low friction
741	40% bronze filled PTFE	General purpose
711	25% carbon graphite filled PTFE	High temperature and high pressures
Energizers – Elastomers		
A-8501	NBR nitrile, 70A	-37 to +129 °C (-35 to +265 °F) General purpose hydraulic and hydrocarbon fluid service
A-8504	NBR nitrile, 70A	-54 to +115 °C (-65 to +240 °F) Low temperature hydraulic fluid service
V-7501	FKM fluoroelastomer 70A	-28 to +204 °C (-18 to +400 °F) High temperatures and pressures. Long wear, general purpose
Anti-extrusion rings – Plastics		
P-2506	Nylon	-40 to +107 °C (-40 to +250 °F) General purpose hydraulic, hydrocarbon
745	Unfilled PEEK	-40 to +232 °C (-40 to +450 °F) Extended temperature, pressure and media resistance

Note: Temperature ranges shown are limited by the functional range of the CT assembly. Materials shown above may have different operating ranges when used in other seal designs. The information contained herein is based on laboratory tests believed to be reliable. It is offered for comparison and guidance to persons who should conduct their own tests in order to determine suitability for any purpose.

CT -3**02000**

Series	Nominal cross section	Size in inches
3	0.187 in.	5 digits for the actual bore diameter
4	0.250 in.	
6	0.375 in.	
8	0.500 in.	

Recommended gland dimensions – inches**Dimensions**

Bore diameter		tolerance	Groove diameter		width	Capped T-seal cross section	Diametrical clearance
D from	to	+/-	d +/-	H	E max		
in.						Series	in.

1.000	2.875	+0.002/-0.000	D - 0.374	+0.000/-0.002	0.424	3	0.025
3.000	4.875	+0.003/-0.000	D - 0.480	+0.000/-0.003	0.579	4	0.030
5.000	16.000	+0.004/-0.000	D - 0.730	+0.000/-0.004	0.750	6	0.035
16.125	22.000	+0.005/-0.000	D - 0.940	+0.000/-0.005	0.750	8	0.035

CT -B**1250****M**

Series	Nominal Cross Section	Actual bore diameter mm	Metric
A	5,0 mm		
B	7,5 mm		
C	10,0 mm		
D	12,5 mm		

Recommended gland dimensions – metric**Dimensions**

Bore diameter		tolerance	Groove diameter		width	Capped T-seal cross section	Diametrical clearance
D from	to	+/-	d +/-	H	E max		
mm						Series	mm

25	74	+0,05/-0,00	D - 10,0	+0,00/-0,05	8,0	A	0,64
75	124	+0,08/-0,00	D - 15,0	+0,00/-0,08	12,0	B	0,76
125	405	+0,10/-0,00	D - 20,0	+0,00/-0,10	16,0	C	0,89
406	560	+0,13/-0,00	D - 25,0	+0,00/-0,13	20,0	D	0,89

The MK/EK design is primarily used in narrow groove pistons often seen in equipment manufactured in the Asia Pacific region.

It is always recommended that groove dimensions be measured before retrofitting Capped T-Seals.

CT - 140

MK

Bore size
mm

Metric
design

Recommended gland dimensions for MK series

Dimensions

Bore diameter		tolerance	Groove diameter	tolerance	width	Diamet- rical clear- ance E max
D incl.	to	+/-	d	+/-	B	
mm						
50	60	+0,05/-0,00	D - 14,00	+0,00/-0,05	9,00	0,64
65	90	+0,08/-0,00	D - 15,00	+0,00/-0,08	11,00	0,64
95	120	+0,10/-0,00	D - 15,00	+0,00/-0,10	12,50	0,76
125	245	+0,13/-0,00	D - 23,00	+0,00/-0,13	16,00	0,89
250	320	+0,13/-0,00	D - 28,00	+0,00/-0,13	17,50	0,89

CT - 7500

EK

Bore size
inches

EK
design

Recommended gland dimensions for EK series

Dimensions

Bore diameter		tolerance	Groove diameter	tolerance	width	Diamet- rical clear- ance E max
D from	to	+/-	d	+/-	B	
in.						
1.75	2.38	+0.002/-0.000	D - 0.551	+0.000/-0.002	0.354	0.025
2.50	3.50	+0.003/-0.000	D - 0.591	+0.000/-0.003	0.433	0.025
3.75	4.75	+0.004/-0.000	D - 0.591	+0.000/-0.004	0.492	0.030
5.00	9.75	+0.005/-0.000	D - 0.906	+0.000/-0.005	0.630	0.035
10.00	12.50	+0.005/-0.000	D - 1.102	+0.000/-0.005	0.689	0.035

Capped T piston seals – metric sizes

D 50 – 270 mm

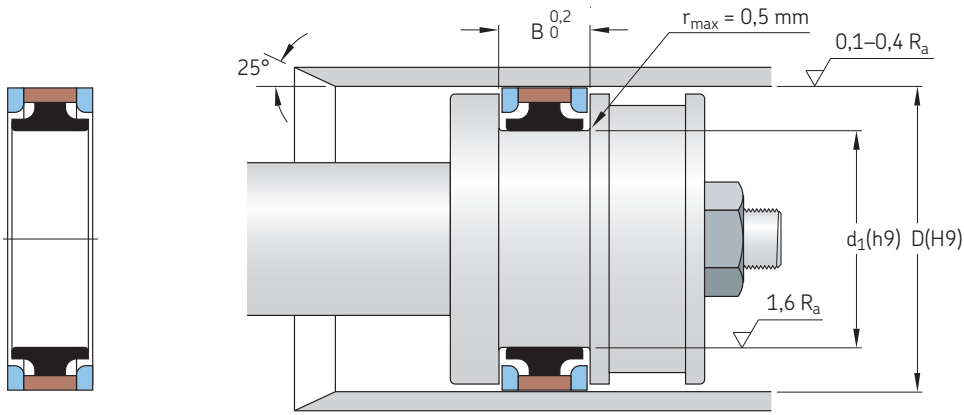

Dimensions			Designation	Dimensions			Designation
Cylinder bore D	Gland diameter d ₁	width B		Cylinder bore D	Gland diameter d ₁	width B	
mm			–	mm			–
50	36	9	CT-050-MK	185	162	16	CT-185-MK
60	46	9	CT-060-MK	190	167	16	CT-190-MK
65	50	11	CT-065-MK	200	177	16	CT-200-MK
70	55	11	CT-070-MK	210	187	16	CT-210-MK
80	65	11	CT-080-MK	220	197	16	CT-220-MK
85	70	11	CT-085-MK	225	202	16	CT-225-MK
90	75	11	CT-090-MK	230	207	16	CT-230-MK
95	80	11	CT-095-MK	240	217	16	CT-240-MK
100	85	12,5	CT-100-MK	250	222	17,5	CT-250-MK
105	90	12,5	CT-105-MK	260	232	17,5	CT-260-MK
110	95	12,5	CT-110-MK	270	242	17,5	CT-270-MK
115	100	12,5	CT-115-MK				
120	105	12,5	CT-120-MK				
125	102	16	CT-125-MK				
130	107	16	CT-130-MK				
135	112	16	CT-135-MK				
140	117	16	CT-140-MK				
145	122	16	CT-145-MK				
150	127	16	CT-150-MK				
160	137	16	CT-160-MK				
165	142	16	CT-165-MK				
170	147	16	CT-170-MK				
180	157	16	CT-180-MK				

Please contact SKF Polyseal for inch sizes.

Guide rings

Close tolerance guide rings

Available in three joint styles: WGT (butt cut), WAT (angle cut) and WST (step cut).

0,05 total thickness range

SKF Polyseal close tolerance guide rings are carefully manufactured to ensure precision clearance control in fluid power systems. This provides longer seal life in dynamic systems.

Reinforced nylon guide rings prevent metal-to-metal contact, allowing metal components to be selected without fear of scoring damage to sealing surfaces.

Close tolerance control ensures minimum clearances and maximum bearing contact to eliminate deflection under load. SKF Polyseal process control and quality assurance provide state-of-the-art repeatability.

Part number descriptions

Metric example

Metric guide rings are designated by MPS at the start of the part number followed by the inside diameter, outside diameter, nominal width and then cut style.

MPS-080-086-050-WGT

Inch example

Standard sized guide rings are designated by nominal cross section, outside diameter, width and then cut style.

125-01.500-0.500-WGT



WGT (butt cut)



WAT (angle cut)



WST (step cut)

Materials number	Description	Temperature	Recommended service
P-2551	40% glass filled nylon	-240 to +121 °C (-400 to +250 °F)	General hydraulics (lubed)
P-2552	40% glass filled nylon w/PTFE	-240 to +121 °C (-400 to +250 °F)	General hydraulics and pneumatic, non-lubed

Typical physical properties of glass reinforced nylon

Property	ASTM test	P-2551	P-2552
Tensile strength, MPa	D638	172	158
Elongation, %	D638	3	2
Flexural modulus, MPa	D790	9650	9300
Compressive strength, MPa	D695	158	138
IZOD impact, strength, J/m notched 3,81 x 6,36 mm	D256	133	107
Hardness, Rockwell R	D795	120	120
Water absorption, %	D570		
24 h		1,2%	1%
Continuous immersion		5%	4%

Wear guide piston application

Groove dimensions

- 1 Subtract 0,03 mm from minimum bore (B_{min}) to allow for ovality and assembly clearance
- 2 Subtract twice maximum wear guide thickness (T_{max}). The result is the maximum groove diameter (G_{max})
- 3 Subtract piston machining tolerance to obtain G_{min}
- 4 To G_{min} , add twice minimum wear guide thickness (T_{min}) to obtain minimum installed wear guide outside diameter
- 5 Subtract twice minimum desired radial piston-to-bore clearance to obtain maximum piston diameter (P_{max}). Subtract piston machining tolerances to obtain P_{min}
- 6 Groove length (L) is equal to nominal wear guide width (W) plus 0,25/0,50 mm.

Seal extrusion gap

Maximum seal extrusion gap (E_{max}) without cylinder bore expansion can be estimated by:

$$E_{max} = B_{max} - (G_{min} + T_{min} + (P_{min} - \frac{G_{min}}{2}))$$

Example

Example bore is 50,00/50,08. Wear guide is 3,0/2,95 mm thick and 15 mm wide. Piston machining tolerance is a total of 0,05 mm. Minimum desired radial piston-to-bore clearance is 0,25 mm.

- 1 $50,00 - 0,03 = 49,97$
- 2 $49,97 - 2 \times 3,0 = 43,97$ (G_{max})
- 3 $43,97 - 0,05 = 43,92$
- 4 $43,92 + 2 \times 2,95 = 49,82$
- 5 $49,82 - 2 \times 0,25 = 49,32$ (P_{max})
 $49,32 - 0,05 = 49,27$ (P_{min})
- 6 $15,00 + 0,25/0,50 = 15,25/15,50$

Seal extrusion gap

$$50,08 - (43,92 + 2,95 + (49,27 - \frac{43,93}{2})) = 0,54 \text{ mm}$$

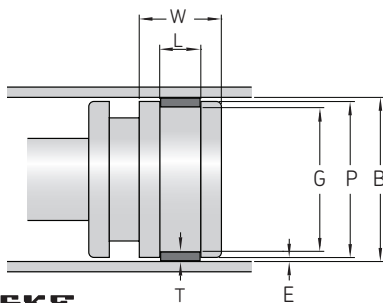

SKF

Wear guide rod application

Groove dimensions

- 1 Add 0,03 mm from maximum rod (R_{max}) to allow for assembly
- 2 Add twice maximum wear guide thickness (T_{max}). The result is the minimum groove diameter (D_{min})
- 3 Add machining tolerances to obtain D_{max}
- 4 From D_{max} , subtract twice the minimum wear guide thickness (T_{min}) to obtain maximum installed wear ring inside diameter
- 5 Add twice the minimum desired radial rod-to-gland bore clearance to obtain minimum gland bore diameter (H_{min}). Add gland machining tolerance to obtain H_{max}
- 6 Groove length (L) is equal to nominal wear guide width (W) plus 0,25/0,50 mm

Seal extrusion gap

Maximum seal extrusion gap (F for new assembly) can be estimated by:

$$E_{max} = H_{max} + D_{max} - H_{max} - \frac{T_{min} + G_{min}}{2}$$

Example

Example rod is 25,00/24,95 mm. Wear guide is 3,0/2,95 mm thick and 10,0 mm wide. Rod gland machining tolerance is a total of 0,05 mm. Minimum desired rod-to-gland clearance is 0,25 mm.

- 1 $25,00 + 0,03 = 25,03$
- 2 $25,03 + 2 \times 3,0 = 31,03$ (D_{min})
- 3 $31,03 + 0,05 = 31,08$ (D_{max})
- 4 $31,08 - 2 \times 2,95 = 25,18$
- 5 $25,18 + 2 \times 0,25 = 25,68$ (H_{min})
 $25,68 + 0,05 = 25,73$ (H_{max})
- 6 $10,00 + 0,25/0,50 = 10,25/10,50$

Seal extrusion gap

$$25,73 + 31,08 - 25,73 - \frac{2,95 + 24,95}{2} = 0,50 \text{ mm}$$

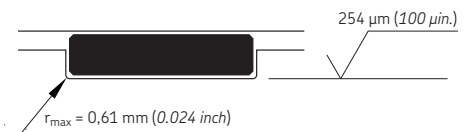
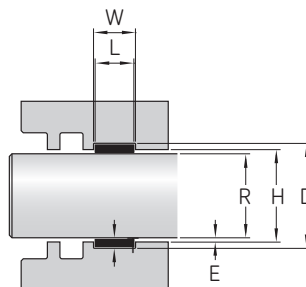

Installation guide

Proper design and seal cross-section selection are the best deterrents to seal installation problems (→ **page 17**: seal cross-section vs. diameter chart).

In addition, devices can be made or purchased which will increase the speed of installation and reduce damage to the seal.

Rod seal installation

Most rod seals can be installed rapidly with the use of the SKF Polyseal installation tool.

Three tool sizes are available:

Seal size I.D.	Tool number
0.750 to 1.125 in.	IT-100
1.500 to 2.000 in.	IT-150
2.000 to 3.000 in.	IT-200

Seals larger than the above sizes can usually be installed easily without the use of tools as long as the cross-section is not too large in relation to the seal's inside diameter. The Lubrithane rod seal is very resilient and will not be damaged by kinking or bending during installation. However, care should be taken not to kink the Fluorotrel or Hytrel rod seal. Before installing a seal, all sharp corners and burrs should be removed from the gland area.

Please see **next page** for installation.

Note!

Inspect seal after installation to assure that all components are properly in place.

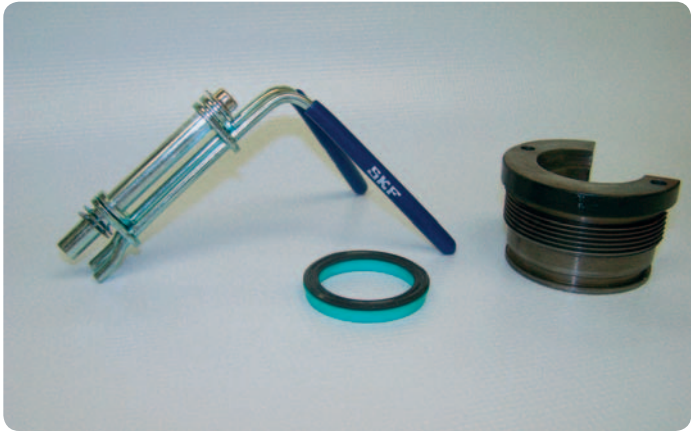

1. Tool, rod housing, SKF Polyseal rod seal



2. Proper tool positioning for grasping rod seal



3. Rod seal properly folded for ease of installation

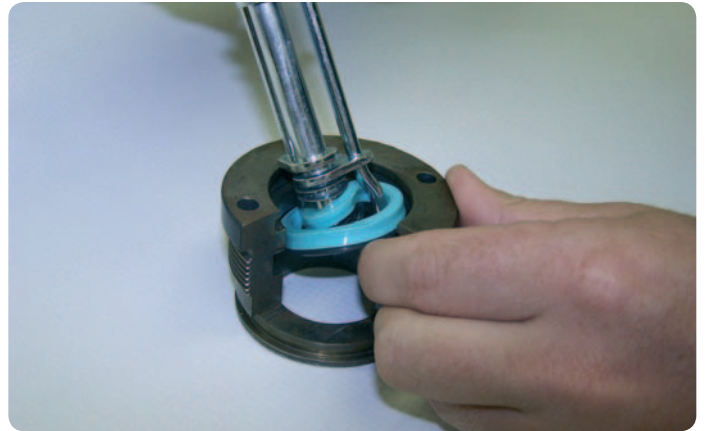

4. Using tool to insert rod seal into the housing



5. Tool positioning rod seal in the groove



6. Rod seal properly installed

Piston seal installation

Seal grooves should be placed as close as practical to the end of the piston, and chamfers should be used to facilitate seal installation. The best method of assembly is rolling the seal into the groove in the same manner as a tire is installed on its rim. Sometimes, cones are used to stretch the seal over the outside diameter of the piston with the use of an arbor press (→ fig. 1).

Assembly bushings can also be used to install the piston into the cylinder to protect the seal from threads, sharp edges, or snap-in grooves (→ fig. 2).

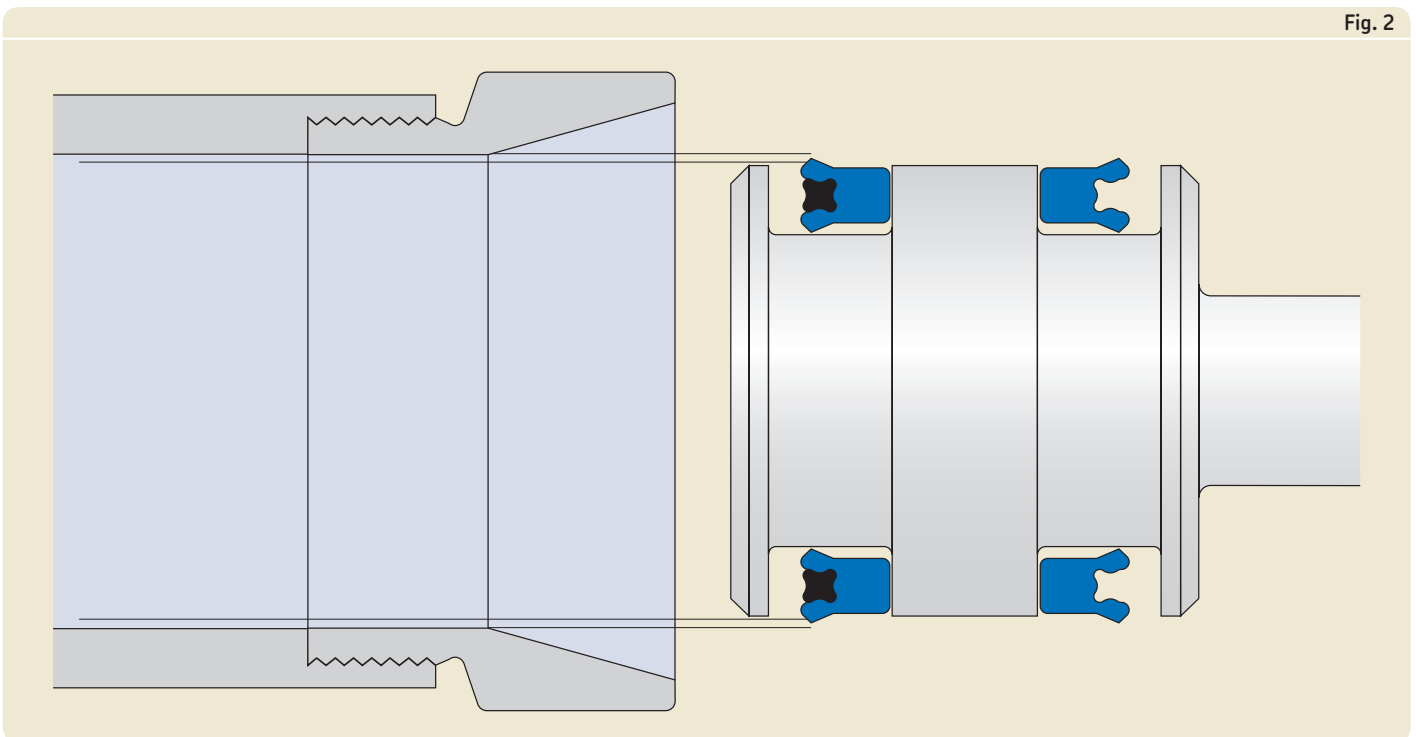
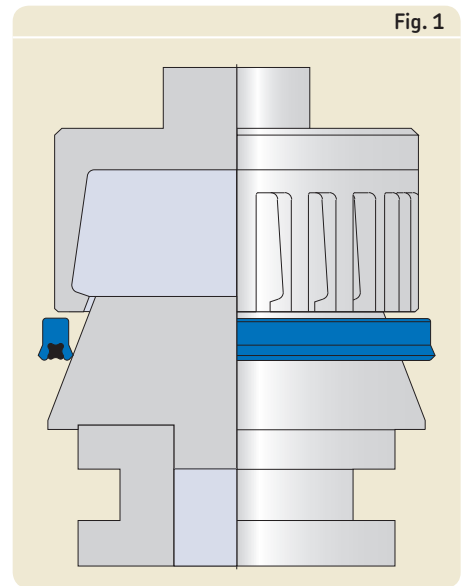

SKF – the knowledge engineering company

From the company that invented the self-aligning ball bearing more than 100 years ago, SKF has evolved into a knowledge engineering company that is able to draw on five technology platforms to create unique solutions for its customers. These platforms include bearings, bearing units and seals, of course, but extend to other areas including: lubricants and lubrication systems, critical for long bearing life in many applications; mechatronics that combine mechanical and electronics knowledge into systems for more effective linear motion and sensorized solutions; and a full range of services, from design and logistics support to condition monitoring and reliability systems.

Though the scope has broadened, SKF continues to maintain the world's leadership in the design, manufacture and marketing of rolling bearings, as well as complementary products such as radial seals. SKF also holds an increasingly important position in the market for linear motion products, high-precision aerospace bearings, machine tool spindles and plant maintenance services.

The SKF Group is globally certified to ISO 14001, the international standard for environmental management, as well as OHSAS 18001, the health and safety management standard. Individual divisions have been approved for quality certification in accordance with ISO 9001 and other customer specific requirements.

With over 120 manufacturing sites worldwide and sales companies in 70 countries, SKF is a truly international corporation. In addition, our distributors and dealers in some 15 000 locations around the world, an e-business marketplace and a global distribution system put SKF close to customers for the supply of both products and services. In essence, SKF solutions are available wherever and whenever customers need them. Overall, the SKF brand and the corporation are stronger than ever. As the knowledge engineering company, we stand ready to serve you with world-class product competencies, intellectual resources, and the vision to help you succeed.



© Airbus – photo: e'm company, H. Goussé

Evolving by-wire technology

SKF has a unique expertise in the fast-growing by-wire technology, from fly-by-wire, to drive-by-wire, to work-by-wire. SKF pioneered practical fly-by-wire technology and is a close working partner with all aerospace industry leaders. As an example, virtually all aircraft of the Airbus design use SKF by-wire systems for cockpit flight control.

SKF is also a leader in automotive by-wire technology, and has partnered with automotive engineers to develop two concept cars, which employ SKF mechatronics for steering and braking. Further by-wire development has led SKF to produce an all-electric forklift truck, which uses mechatronics rather than hydraulics for all controls.

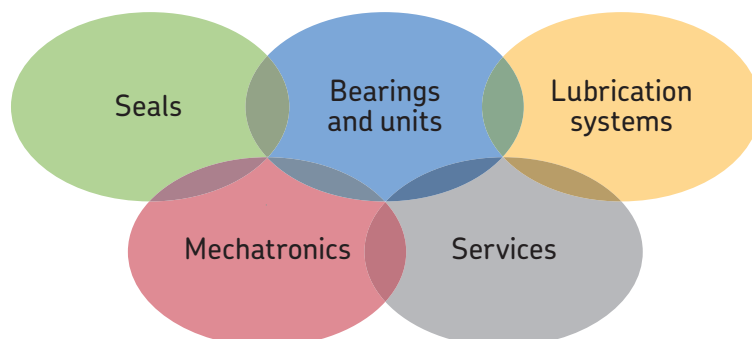



Harnessing wind power

The growing industry of wind-generated electric power provides a source of clean, green electricity. SKF is working closely with global industry leaders to develop efficient and trouble-free turbines, providing a wide range of large, highly specialized bearings and condition monitoring systems to extend equipment life of wind farms located in even the most remote and inhospitable environments.



Working in extreme environments

In frigid winters, especially in northern countries, extreme sub-zero temperatures can cause bearings in railway axleboxes to seize due to lubrication starvation. SKF created a new family of synthetic lubricants formulated to retain their lubrication viscosity even at these extreme temperatures. SKF knowledge enables manufacturers and end user customers to overcome the performance issues resulting from extreme temperatures, whether hot or cold. For example, SKF products are at work in diverse environments such as baking ovens and instant freezing in food processing plants.



Developing a cleaner cleaner

The electric motor and its bearings are the heart of many household appliances. SKF works closely with appliance manufacturers to improve their products' performance, cut costs, reduce weight, and reduce energy consumption. A recent example of this cooperation is a new generation of vacuum cleaners with substantially more suction. SKF knowledge in the area of small bearing technology is also applied to manufacturers of power tools and office equipment.



Maintaining a 350 km/h R&D lab

In addition to SKF's renowned research and development facilities in Europe and the United States, Formula One car racing provides a unique environment for SKF to push the limits of bearing technology. For over 60 years, SKF products, engineering and knowledge have helped make Scuderia Ferrari a formidable force in F1 racing. (The average racing Ferrari utilizes around 150 SKF components.) Lessons learned here are applied to the products we provide to automakers and the aftermarket worldwide.



Delivering Asset Efficiency Optimization

Through SKF Reliability Systems, SKF provides a comprehensive range of asset efficiency products and services, from condition monitoring hardware and software to maintenance strategies, engineering assistance and machine reliability programmes. To optimize efficiency and boost productivity, some industrial facilities opt for an Integrated Maintenance Solution, in which SKF delivers all services under one fixed-fee, performance-based contract.



Planning for sustainable growth

By their very nature, bearings make a positive contribution to the natural environment, enabling machinery to operate more efficiently, consume less power, and require less lubrication. By raising the performance bar for our own products, SKF is enabling a new generation of high-efficiency products and equipment. With an eye to the future and the world we will leave to our children, the SKF Group policy on environment, health and safety, as well as the manufacturing techniques, are planned and implemented to help protect and preserve the earth's limited natural resources. We remain committed to sustainable, environmentally responsible growth.



® SKF is a registered trademark of the SKF Group.

™ Buffer Seal, Capped T-seal, Crown seal, Fluorotrel, Lubrithane and Spectraseal are trademarks of the SKF Group.

Ekonol is a registered trademark of Carborundum Company.

© SKF Group 2010

The contents of this publication are the copyright of the publisher and may not be reproduced (even extracts) unless prior written permission is granted. Every care has been taken to ensure the accuracy of the information contained in this publication but no liability can be accepted for any loss or damage whether direct, indirect or consequential arising out of the use of the information contained herein.

PUB SE/P2 06864 EN · January 2011

Printed in USA on environmentally friendly paper.

skf.com