

Relubrication-free solutions for industrial air handling units

- Easy to install
- Long service life
- Relubrication-free
- Reduced power consumption

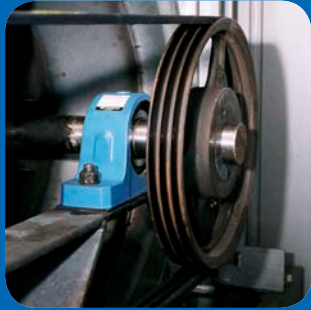

Mount a defense against rising costs

Excessive vibrations in an industrial air handling unit can pose a constant threat to service life and performance. For OEMs, that typically means warranty claims, and customer satisfaction issues. Often, the problem is the result of a bearing that was not mounted properly, or that loosened its grip on the shaft.

It takes time and skill to accurately install a bearing that will be used in a split housing. If the bearing is not installed properly on its adapter sleeve, it will either be too tight or too loose. Either way, the bearing and the seal are prone to fail prematurely.

When installing a bearing unit on a shaft, the installation process is faster and easier than with a split housing. However, most bearing units have a locking mechanism that can loosen over time – and in many cases, the locking mechanism can contribute to shaft vibrations that eventually cause the bearing and seal to fail prematurely. With either of these bearing configurations there is a distinct risk that the bearing and/or seal will not achieve the expected service life.

Another contributor to premature bearing failure is relubrication. Bearings that fail prematurely for lubrication-related reasons typically fail for one or a combination of the following:

- insufficient lubricant
- excessive amount of lubricant
- lubricant incompatibility
- dirt in the lubricant.



Reduce costs and environmental impact

Relubrication-free ConCentra units can save approximately 3 kg of grease per fan during its lifetime, and reduce electrical consumption by 2 000 kWh per year. Maybe not enormous savings if you look at one fan; but imagine the savings if all fans were equipped with SKF ConCentra units.

The relubrication-free ConCentra solution

With patented SKF ConCentra ball and roller bearing units, you can build extended performance into your fans from day one. Not only are these bearing units easy to mount on a shaft, they are pre-greased, sealed and do not need to be lubricated before or after they have been installed. SKF ConCentra bearing units are filled with a premium bearing grease, and do not require relubrication under normal conditions. This reduces maintenance costs, while eliminating premature bearing and seal failures caused by under or over greasing the bearings or using the wrong grease (See chart).

An innovative locking system

During installation the mating surfaces are axially displaced by tightening the grub screws, which forces the bearing ring to expand and the sleeve to contract, providing a true concentric, tight friction joint with the shaft.

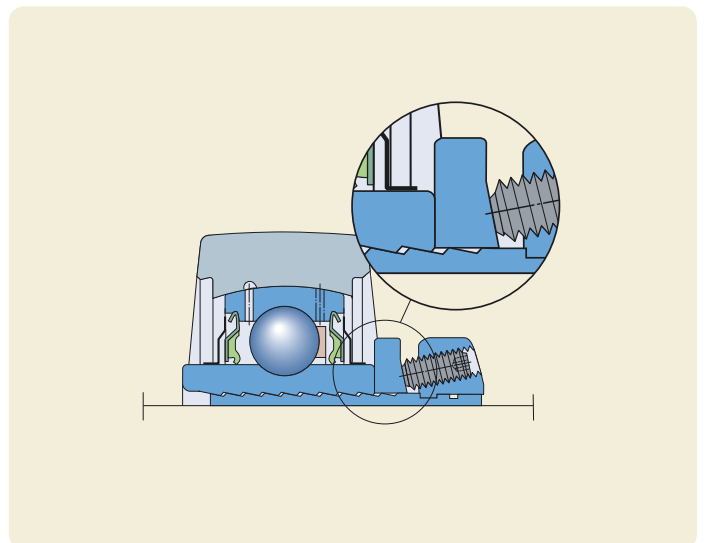

Relationship between operating temperature and speed for relubrication-free air handling unit

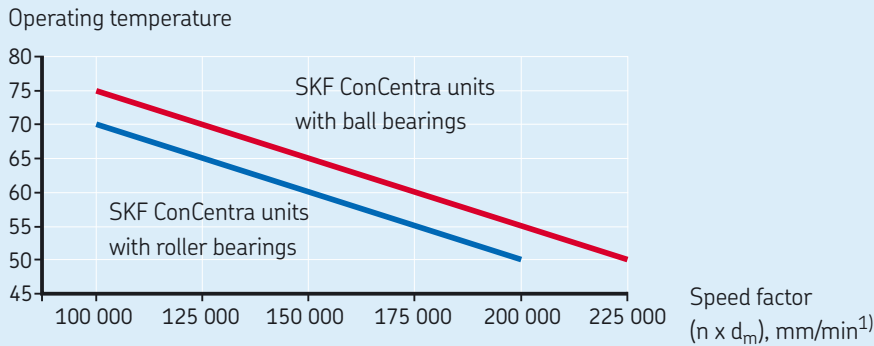

¹) For d_m values see the product tables

Seal for roller bearing unit

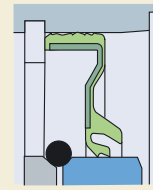

Seal for ball bearing unit

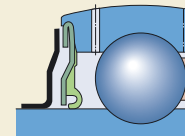

Another advantage of SKF ConCentra bearing units is that once they are mounted, they maintain their grip on the shaft until they are removed. No longer is there a need to check that collars and screws are tight – and because the SKF ConCentra locking system is concentric, these units do not contribute to the vibrations that can be caused by other locking mechanisms.

An innovative locking system

The SKF ConCentra stepped sleeve, a masterpiece of locking technology, is the real innovation behind the SKF ConCentra bearing unit. The locking concept is based on two mating surfaces with precision-engineered inclined serrations on their contact surfaces. By tightening the grub screws in the mounting ring, the pressure ring forces the inner ring up the inclined planes of the stepped sleeve. This provides a true concentric fit that is tight, accurate and highly reliable, even under the most difficult operating conditions.

Fast, easy Installation

SKF ConCentra bearing units are sealed, greased and ready to mount right out of the box. Unlike other bearing units, the SKF ConCentra bearing unit is balanced (not offset), and designed for easy installation and removal. In fact, an SKF ConCentra unit installs 20 to 30 minutes faster than a sleeve mounted bearing in a split housing. For OEMs, this translates to reduced costs in time and manpower.

Outstanding durability

Designed for outstanding reliability and long service life, SKF ConCentra bearing units can accommodate shaft deflections and misalignment.

Integral seals for long service life

SKF ConCentra bearing units feature integral seals that provide additional protection from contaminants, and contribute to long bearing service life.

Seals for SKF ConCentra roller bearing units

These unique seals can accommodate up to 1,5 degrees of misalignment and are designed to accommodate axial displacement of the bearing when the unit is in the non-locating bearing position.

Seals for SKF ConCentra ball bearing units

The ball bearing in an SKF ConCentra unit is sealed on both sides with the highly efficient SKF “Superagriseal” which is complemented by flingers to considerably enhance the sealing effect without increasing friction.

Condition monitoring ready

The SKF ConCentra bearing housing is designed to accommodate condition monitoring applications. Sensors can easily be mounted to three flat surfaces which are perpendicular to each other on the sides of the housing.

High-performance housing for added protection

The design of SKF’s proven plumber block housings add an additional measure of durability and protection for SKF ConCentra bearing units, while contributing to easy installation. The housing is made of cast iron that encloses the bearing to protect it from external damage. The stiff design helps the housing retain its form, and an epoxy paint coating provides very good corrosion resistance. A solventless rust inhibitor protects blank surfaces. Oblong attachment holes in the base make it easy to accurately align the bearing unit and shaft.

SKF ConCentra ball bearing units for metric shafts

d_a 25 – 60 mm

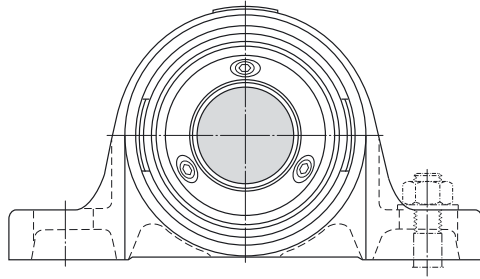
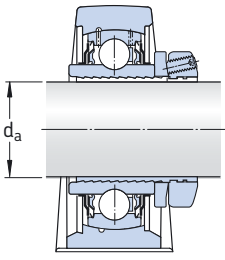

SY.. PF

Dimensions Shaft size	Basic load ratings		Fatigue load limit	Speed limit	Bearing mean diameter	Designation
	dynamic	static				
d_a	C	C_0	P_u		d_m	
mm	kN		kN	r/min	mm	–
25	14	7,8	0,335	7 000	38,5	SY 25 PF
30	19,5	11,2	0,475	6 300	46	SY 30 PF
35	25,5	15,3	0,655	5 300	53,5	SY 35 PF
40	30,7	19	0,8	4 800	60	SY 40 PF
45	33,2	21,6	0,915	4 300	65	SY 45 PF
50	35,1	23,2	0,98	4 000	70	SY 50 PF
55	43,6	29	1,25	3 600	77,5	SY 55 PF
60	52,7	36	1,53	3 400	85	SY 60 PF

SKF ConCentra ball bearing units for inch shafts

d_a 1 – 2 ¹⁵/₁₆ in

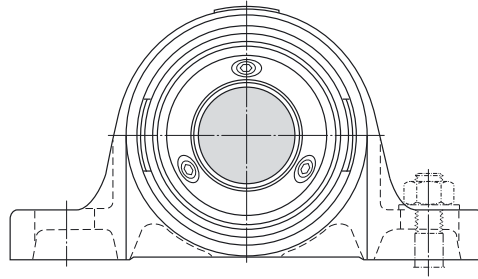
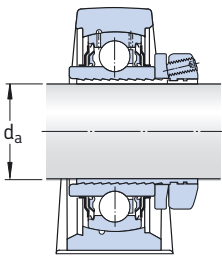

SY .. PF/AH

Dimensions Shaft size	Basic load ratings		Fatigue load limit	Speed limit	Bearing mean diameter	Designation
	dynamic	static				
d_a	C	C_0	P_u		d_m	
in	kN		kN	r/min	mm	–
1	14	7,8	0,335	7 000	38,5	SY 1. PF/AH
1 ³ / ₁₆	19,5	11,2	0,475	6 300	46	SY 1.3/16 PF/AH
1 ¹ / ₄	25,5	15,3	0,655	5 300	53,5	SY 1.1/4 PF/AH
1 ³ / ₈	25,5	15,3	0,655	5 300	53,5	SY 1.3/8 PF/AH
1 ⁷ / ₁₆	25,5	15,3	0,655	5 300	53,5	SY 1.7/16 PF/AH
1 ¹ / ₂	30,7	19	0,8	4 800	60	SY 1.1/2 PF/AH
1 ¹¹ / ₁₆	33,2	21,6	0,915	4 300	65	SY 1.11/16 PF/AH
1 ¹⁵ / ₁₆	35,1	23,2	0,98	4 000	70	SY 1.15/16 PF/AH
2 ³ / ₁₆	43,6	29	1,25	3 600	77,5	SY 2.3/16 PF/AH
2 ⁷ / ₁₆	52,7	36	1,53	3 400	85	SY 2.7/16 PF/AH
2 ¹¹ / ₁₆	62,4	44	1,86	3 000	97,5	SY 2.11/16 PF/AH
2 ¹⁵ / ₁₆	66,5	49	2,04	2 600	102,5	SY 2.15/16 PF/AH

ConCentra roller bearing units for metric shafts

d_a 35 – 75 mm

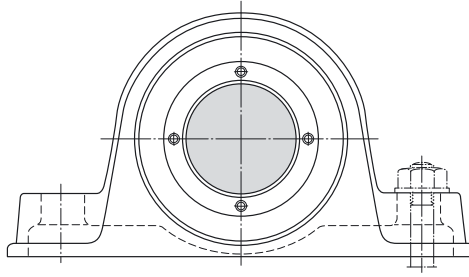
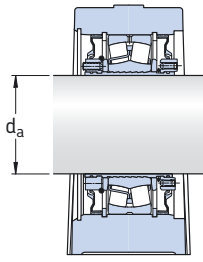

SYT .. FW

SYT .. LW

Dimensions Shaft size	Basic load ratings		Fatigue load limit	Speed limit	Bearing mean diameter	Designations	
	dynamic	static				Locating	Non-locating
d_a	C	C_o	P_u		d_m		
mm	kN		kN	r/min	mm	–	
35	86,5	85	9,3	4 400	53,5	SYT 35 FW	SYT 35 LW
40	96,5	90	9,8	4 000	60	SYT 40 FW	SYT 40 LW
45	102	98	10,8	3 700	65	SYT 45 FW	SYT 45 LW
50	104	108	11,8	3 500	70	SYT 50 FW	SYT 50 LW
55	125	127	13,7	3 250	77,5	SYT 55 FW	SYT 55 LW
60	156	166	18,6	3 000	85	SYT 60 FW	SYT 60 LW
65	193	216	24	2 900	92,5	SYT 65 FW	SYT 65 LW
70	208	228	25,5	2 650	97,5	SYT 70 FW	SYT 70 LW
75	212	240	26,5	2 600	102,5	SYT 75 FW	SYT 75 LW

ConCentra roller bearing units for inch shafts

d_a 1 7/16 – 4 in

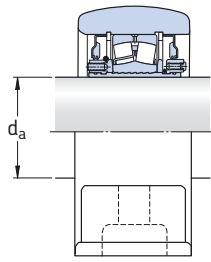

SYR .. NHW
SYR .. NW

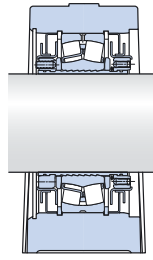

SYE .. NHW
SYE .. NW

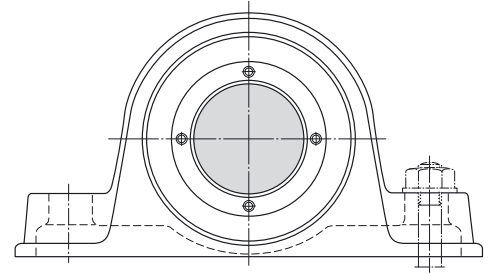

Dimensions Shaft size	Basic load ratings		Fatigue load limit	Speed limit	Bearing mean diameter	Designations SYR units Locating	Non-locating	SYE units	
	dynamic	static						Locating	Non-locating
d_a	C	C_0	P_u		d_m				
in	kN		kN	r/min	mm	–			
1 7/16	96,5	90	9,8	4 000	60	SYR 1.7/16 NHW SYR 1.7/16 NW	SYR 1.7/16 NW	SYE 1.7/16 NHW	SYE 1.7/16 NW
1 1/2	96,5	90	9,8	4 000	60	SYR 1.1/2 NHW SYR 1.1/2 NW	SYR 1.1/2 NW	SYE 1.1/2 NHW	SYE 1.1/2 NW
1 11/16	102	98	10,8	3 700	65	SYR 1.11/16 NHW SYR 1.11/16 NW	SYR 1.11/16 NW	SYE 1.11/16 NHW	SYE 1.11/16 NW
1 3/4	102	98	10,8	3 700	65	SYR 1.3/4 NHW SYR 1.3/4 NW	SYR 1.3/4 NW	SYE 1.3/4 NHW	SYE 1.3/4 NW
1 15/16	104	108	11,8	3 500	70	SYR 1.15/16 NHW SYR 1.15/16 NW	SYR 1.15/16 NW	SYE 1.15/16 NHW	SYE 1.15/16 NW
2	104	108	11,8	3 500	70	SYR 2. NHW SYR 2. NW	SYR 2. NW	SYE 2. NHW	SYE 2. NW
2 3/16	125	127	13,7	3 250	77,5	SYR 2.3/16 NHW SYR 2.3/16 NW	SYR 2.3/16 NW	SYE 2.3/16 NHW	SYE 2.3/16 NW
2 7/16	193	216	24	2 900	92,5	SYR 2.7/16 NHW SYR 2.7/16 NW	SYR 2.7/16 NW	SYE 2.7/16 NHW	SYE 2.7/16 NW
2 1/2	193	216	24	2 900	92,5	SYR 2.1/2 NHW SYR 2.1/2 NW	SYR 2.1/2 NW	SYE 2.1/2 NHW	SYE 2.1/2 NW
2 11/16	212	240	26,5	2 600	102,5	SYR 2.11/16 NHW SYR 2.11/16 NW	SYR 2.11/16 NW	SYE 2.11/16 NHW	SYE 2.11/16 NW
2 3/4	212	240	26,5	2 600	102,5	SYR 2.3/4 NHW SYR 2.3/4 NW	SYR 2.3/4 NW	SYE 2.3/4 NHW	SYE 2.3/4 NW
2 15/16	212	240	26,5	2 600	102,5	SYR 2.15/16 NHW SYR 2.15/16 NW	SYR 2.15/16 NW	SYE 2.15/16 NHW	SYE 2.15/16 NW
3	212	240	26,5	2 600	102,5	SYR 3. NHW SYR 3. NW	SYR 3. NW	SYE 3. NHW	SYE 3. NW
3 7/16	325	375	39	2 200	125	SYR 3.7/16 NHW SYR 3.7/16 NW	SYR 3.7/16 NW	SYE 3.7/16 NHW	SYE 3.7/16 NW
3 1/2	325	375	39	2 200	125	SYR 3.1/2 NHW SYR 3.1/2 NW	SYR 3.1/2 NW	SYE 3.1/2 NHW	SYE 3.1/2 NW
3 15/16	425	490	49	2 000	140	SYR 3.15/16 NHW SYR 3.15/16 NW	SYR 3.15/16 NW	SYE 3.15/16 NHW	SYE 3.15/16 NW
4	425	490	49	2 000	140	SYR 4. NHW SYR 4. NW	SYR 4. NW	SYE 4. NHW	SYE 4. NW

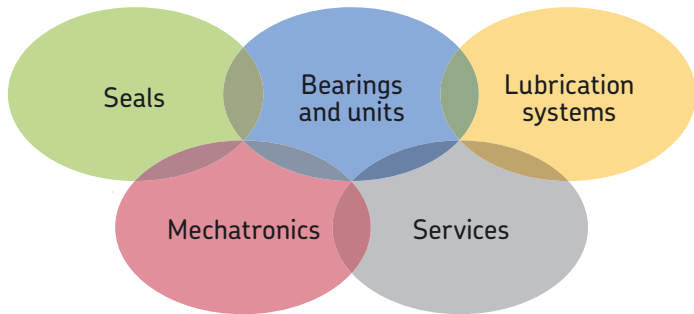

The power of knowledge engineering

Drawing on five areas of competence and application-specific expertise amassed over 100 years, SKF brings innovative solutions to OEMs and production facilities in every major industry worldwide.

These five competence areas include bearings and units, seals, lubrication systems, mechatronics (combining mechanical and electronics into intelligent systems), and a wide range of services, from 3D computer modeling to advanced condition monitoring and reliability systems.

A global presence assures SKF customers uniform quality standards and universal product availability.

© SKF is a registered trademark of the SKF Group

™ SKF Explorer is a trademark of the SKF Group

© SKF Group 2007

The contents of this publication are the copyright of the publisher and may not be reproduced (even extracts) unless permission is granted. Every care has been taken to ensure the accuracy of the information contained in this publication but no liability can be accepted for any loss or damage whether direct, indirect or consequential arising out of the use of the information contained herein.

Publication **6578 EN** • September 2007

Printed in Sweden on environmentally friendly paper.

